

# MS1244

## Air Eliminator

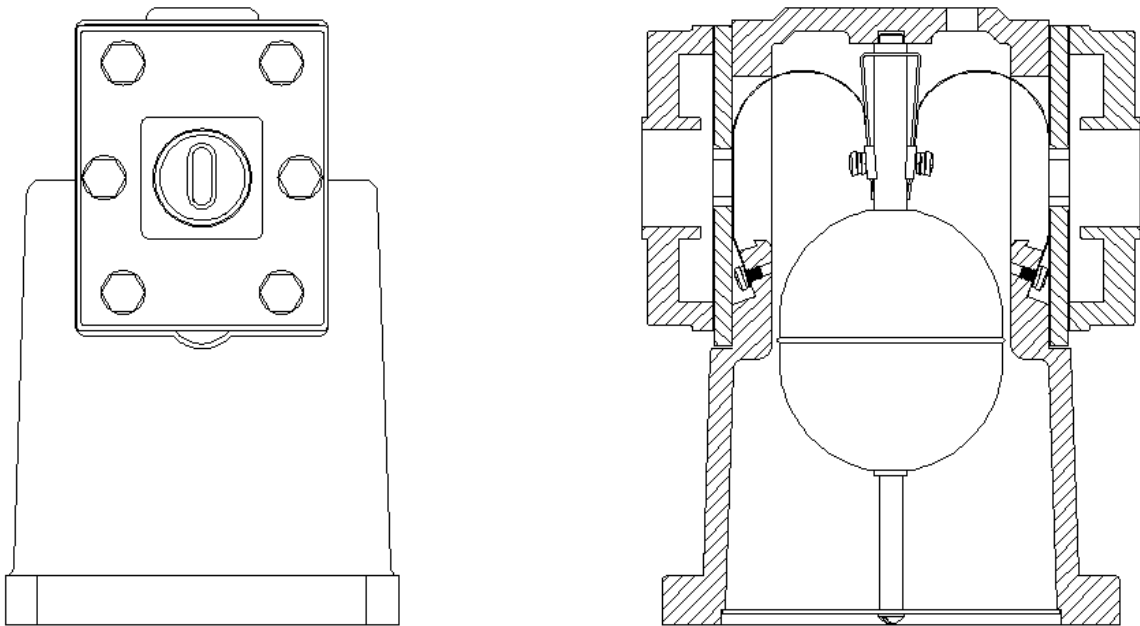

**MS1244A Assembly used in WM50 models**

# Principle Operation & Maintenance Manual

# Warning Symbols



## CAUTION

Follow the warning instructions within the following information to avoid equipment failure, personal injury or death.



## TURN POWER OFF

Before performing any maintenance, be sure to turn system power off to avoid any potential electric spark



## FLAMMABLE

Flammable liquids and their vapors may cause a fire or explosion if ignited.



## EYE PROTECTION

Pressurized systems may cause hazardous leaks and spray that may be dangerous for your eyes. Always wear eye protection around pressurized systems and its hazardous liquids.



## INJURY

Wear gloves for protection from hazardous liquids that may cause irritation or burns.



## READ

Read and understand all related manuals thoroughly. The Engineering and OIM manuals will provide the knowledge for all systems, maintenance and operation proce-

# MS1244 Air Eliminator

An air eliminator is a device designed to extract free or accumulated volumes of air or vapor from a liquid dispensing system to achieve accurate measurement results. Each air eliminator must be vented back to a storage tank or into a special "catch" tank vented to atmospheric pressure as the air or vapor released will contain a small amount of liquid.

The Macnaught MS1244 series air eliminator mechanism is a reed curtain valve consisting of two stainless steel reed strips operating in conjunction with a valve plate. One end of each reed is fastened to a float and the other is attached to the housing. The counter balancing reeds allow the float to have maximum sensitivity of air or vapor present in the system. The float assembly is normally closed when air or vapor is absent from the liquid. The float assembly opens when free air or vapor accumulates in the housing. The displacement of the air or vapor lowers the liquid level within the housing, dropping the float and releasing the air or vapor out of the orifice on the valve plates. The efficient design of the float and valve plate assembly allow the air eliminator mechanism to operate at zero or maximum pressure, without stress or fatigue. The MACNAUGHT MS1244 air eliminator mechanism will release approximately 150 CFM (cubic feet per minute) at full capacity.



MS1244 Air Eliminator

## MS1244 Air Eliminator (Continued)

The efficiency of the air eliminator depends on the amount of backpressure against the air eliminator. If the backpressure at the air eliminator outlet is higher than the venting valve to the storage tank plus the diameter and length of the vent line, then the air eliminator will function correctly. The backpressure at the air eliminator will depend upon the pressure drop of the items downstream of the air eliminator. If the backpressure is not sufficient, some air can be allowed through the meter.

Additional restrictions down stream of the air eliminator may be in the form of orifice plates or implementing a spring-loaded wafer check valve between the air eliminator and flow meter.

The specification of air elimination varies greatly on the design of each system and the potential source of the air in the line. Once free air becomes encapsulated in the fluid, particularly at high flow rates, the air will simply be carried along through the meter, as the air eliminator cannot remove this encapsulated air. There are several factors that must be considered for proper air elimination; types of pumps, vacuum seal leaks, above and below ground tanks, receiving and delivering pipelines, etc.

It is far better to avoid pumping any air or vapor than to attempt to separate and remove it after it has been mixed with the liquid in the pump. Avoid designing a system that receives and dispenses product through the same flow meter or purging the lines before the system sits idle. Each system should have a dedicated meter and a way to refill purged lines without introducing air into the meter.

The choice of pump to be used can effect the amount of air or vapor that is introduced into the system. A centrifugal pump normally requires the MS1244-air eliminator for nominal air present in the system. Centrifugal pumps internally bypass product when a valve is closed down stream, this is an inherent safety feature of centrifugal pumps. However if the RPM of the motor is more than required, the centrifugal pump may cavitate and create encapsulated air within the operating system. The suggestion would be to reduce the motor RPM rather than use the a bulk air eliminator.

A positive displacement pump, will move any air that is in the system. A meter can have multiple problems if the rotary or gear pump is installed incorrectly. Cavitation, pump pressure and mechanical seal leaks are common among these problems. Higher flow rates for products that "foam", such as #2 fuel oil or kerosene, tends to be a problem for air eliminators to operate efficiently. Turning down the pump pressure to reduce the agitation of the product will help reduce encapsulated air or vapor in the system. On PTO driven pumps, install an engine control device (throttling valve) that regulates the flow of liquid based on the engine

# MS1244 Air Eliminator Types

## SP - Standard Petroleum

Suitable for refined petroleum products such as Leaded and Unleaded Gasoline, Fuel Oils, Diesel, Bio-Diesel, Kerosene, Jet Fuels, Vegetable Oils, Motor Oils, Ethylene Glycol (Antifreeze), etc.

## IP - Industrial Products

Suitable for Industrial Chemicals, General Solvents and many other liquids; such as Liquid Sugars, Corn Syrup, Soy Bean Oil, Shortenings, Latex Products, Adhesives, etc.

## SS - Stainless Steel

Suitable for the same liquids as the SP, SPD, IP and AF air eliminators, but includes food processing and special handling fluids such as Nitric, Phosphorus and Glacial Acetic Acids, etc.

# MS1244 Air Eliminator Material of Construction

Description	SP (Standard)	IP	SS
Housing	Hardcoat Anodized Aluminum	Hardcoat Anodized Aluminum	Stainless Steel
Valve Covers	Hardcoat Anodized Aluminum	Hardcoat Anodized Aluminum	Stainless Steel
Float Assembly	Stainless Steel	Stainless Steel	Stainless Steel
Hardware	Stainless Steel	Stainless Steel	Stainless Steel
O-ring Seals	Viton®	Teflon®	Teflon®
Valve Plate Seal	Viton®	Simriz®	Simriz®

*Viton® is a registered trademark of E.I. DuPont de Nemours & Co.*

*Simriz® is a registered trademark of Freudenberg-NOK.*

*Teflon® is a registered trademark of Dupont Dow Elastomers, L.L.C.*

# MS1244 Air Eliminator Performance Specification

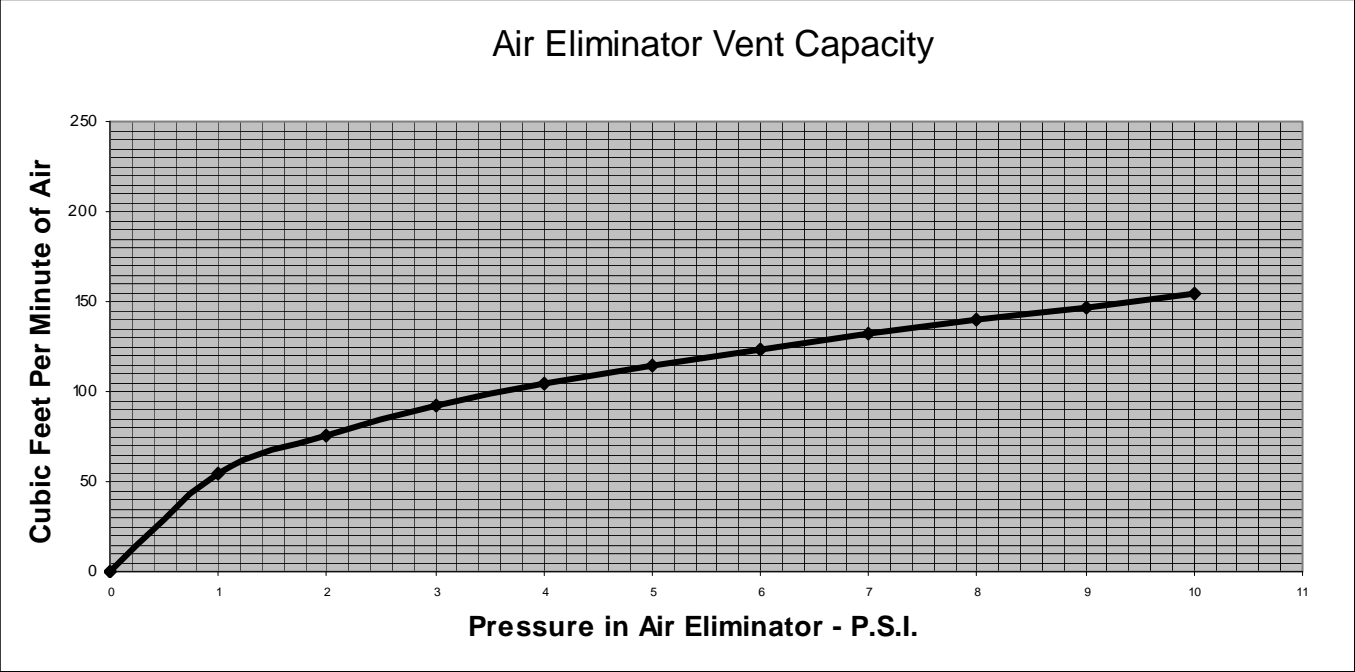

# MS1244 Air Eliminator Dimensions

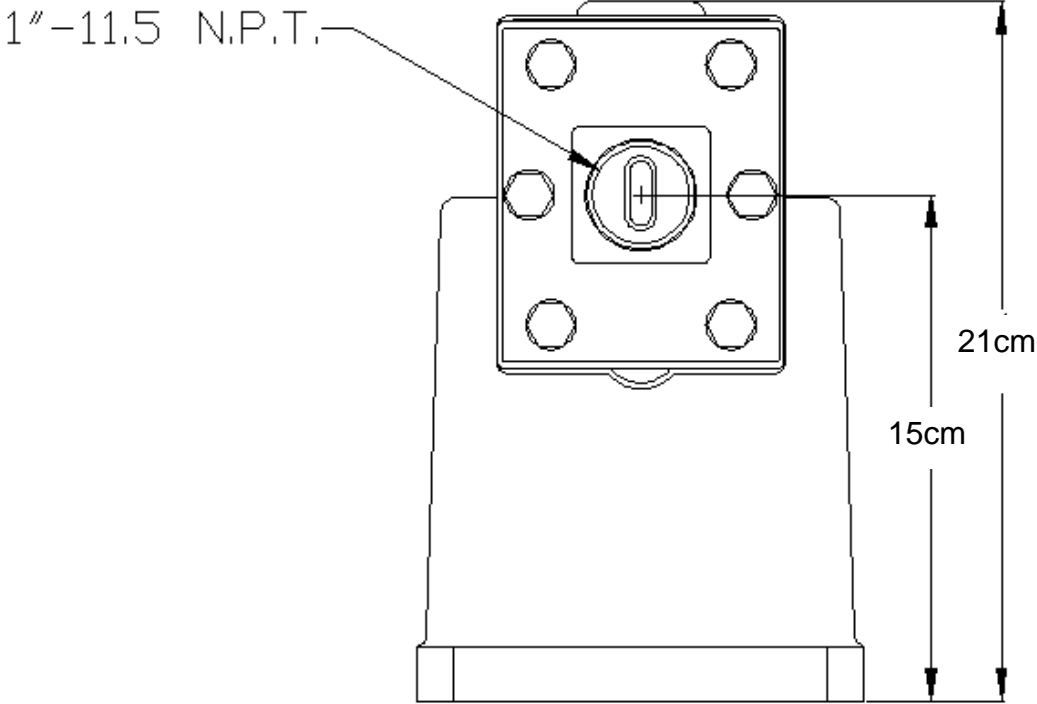

# MS1244 Air Eliminator Assembly

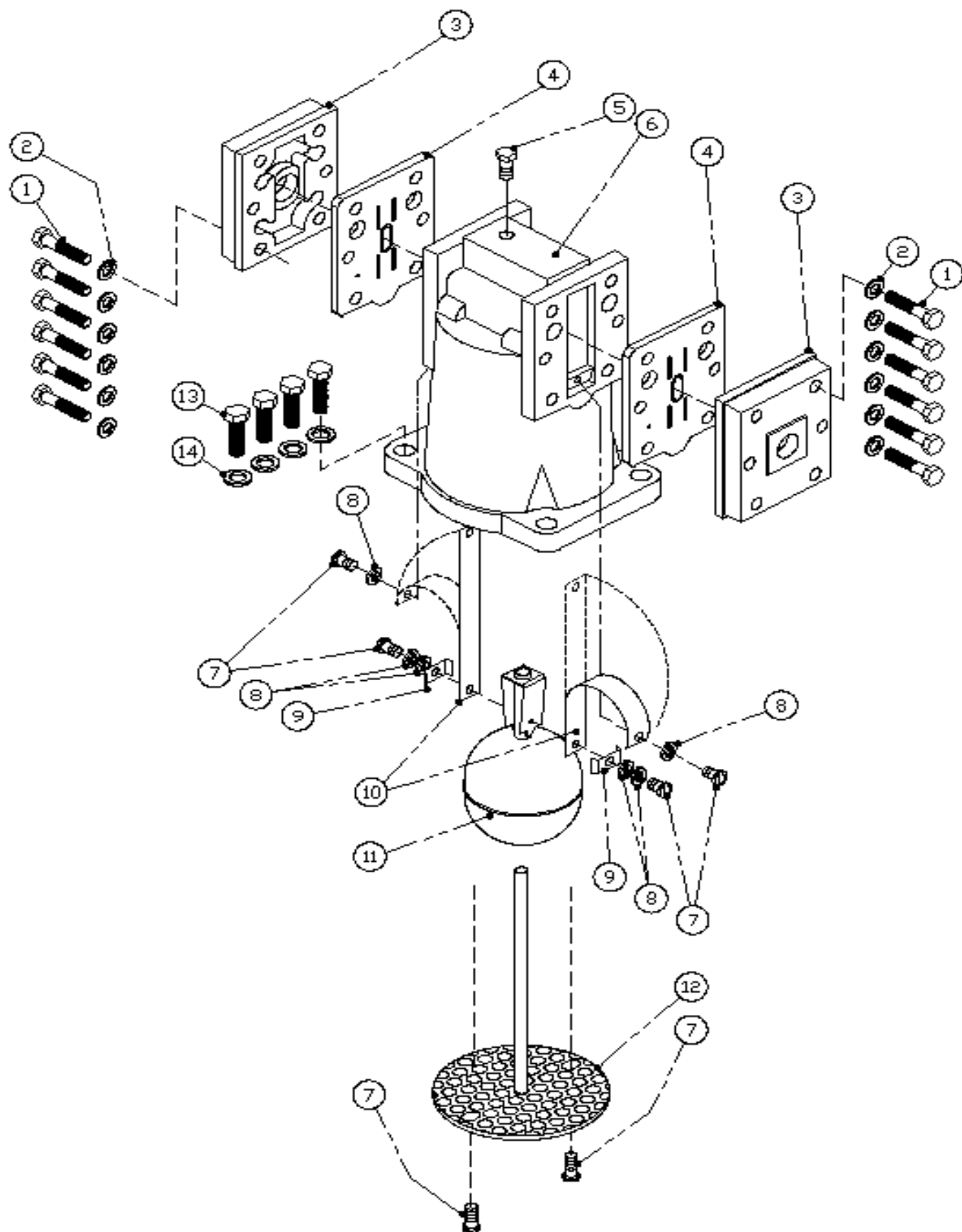

## MS1244 Air Eliminator Assembly

Item	Description	Qty	MS1244
			SP
1	Cap Screw	12	AE050
2	Ring Washer	12	AE051
3	Outlet Cover	2	AE010
4	Encapsulated Valve Plate	2	AE205
5	Plug	1	AE014
6	Air Eliminator Housing	1	AE020
7	Screw	4	AE030
8	Split Lock Washer	4	AE017
9	Retaining Clip	2	AE012
10	Reed Valve	2	AE007
11	Float Assembly	1	AE013
12	Diffuser and Shaft Assembly	1	AE035
13	Flat Washer	4	AE015
14	Cap Screw	4	AE016

## Disassembly of MS1244 Air Eliminator Assembly

### ***!WARNING!***

All internal pressure must be relieved to ZERO (0) pressure before beginning disassembly of meter or components

- 1) Using a 1/2" wrench or socket, remove the cover screws from air eliminator cover plate.
- 2) Remove cover plate.
- 3) Remove valve plate, inspect and replace as needed.



- 1) To remove the air eliminator assembly, remove the four screws and washers attaching it to the strainer assembly.
- 2) Using a flathead screwdriver, remove the screws attaching reed valves to air eliminator housing.
- 3) Remove the two screws on the diffuser screen.
- 4) Slide out diffuser shaft assembly.
- 5) Remove the two screws attaching reed valve to the float assembly. Inspect and replace reed valves as needed.

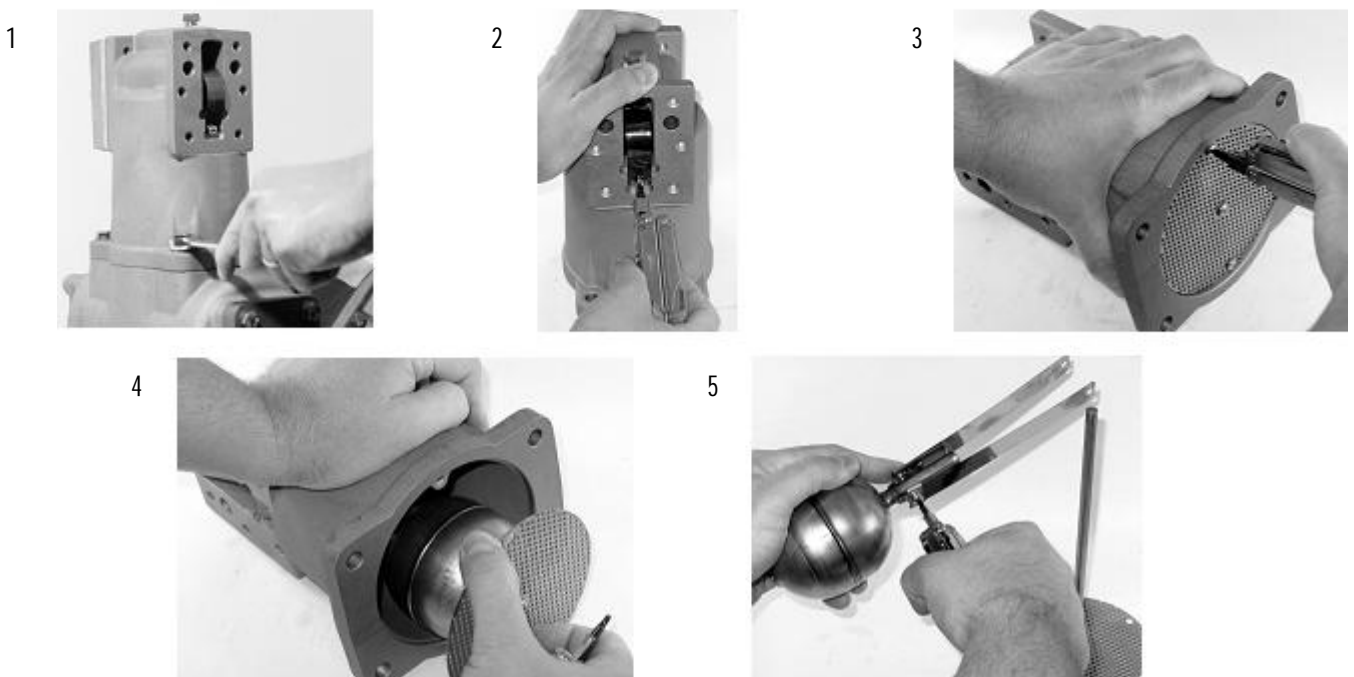

# MS1244 Air Eliminator Trouble Shooting



**PROBLEM:** Product is flowing from the Air Eliminators vents

- A) Foreign matter located in between valve plate and metal reeds.
- B) The valve plate may be worn through service life.
- C) The Teflon reed strip may be worn through service life.
- D) The float may have been punctured, containing liquid, not allowing the float to rise and seal the air vents.
- E) The float may have been ruptured from a surge of pressure within the system.
- F) The metal reeds may be fatigued and requires replacement.
- G) The metal reeds may be out of alignment with the seal plate.

**PROBLEM:** The meter is still registering air within the system

There can be numerous reasons why the meter may still register air. First look at the system configuration and see where air is being introduced into the system. Then determine if the meter is registering “free air” or “entrained air”. Free Air is much easier to remove from the metering system and may require the use of the Spring Loaded Back Check Valve and/or the Differential Air Check Valve and/or High Volume Strainer to help the air eliminator operate more effectively. Entrained Air is much more difficult to remove. Typically the best way to eliminate Entrained Air will be to remove the air source of entry into the system. Some examples are from cavitating pumps and leaking pump/valve seals. A High Volume Strainer may help accumulate the liquid long enough to disperse the Entrained Air from the system. See Air Elimination in the Service Manual for more information.

- A) The air return line is not the required minimum of 1/2” ID.
- B) The metering system has no sufficient way of eliminating the air to atmosphere. Example: Incorrectly installed “Catch Can” reservoir (lower than the air eliminator itself), or the reservoir is allowed to become full, incorrectly sized vent, etc...)

# MS1244 Strainer Assembly

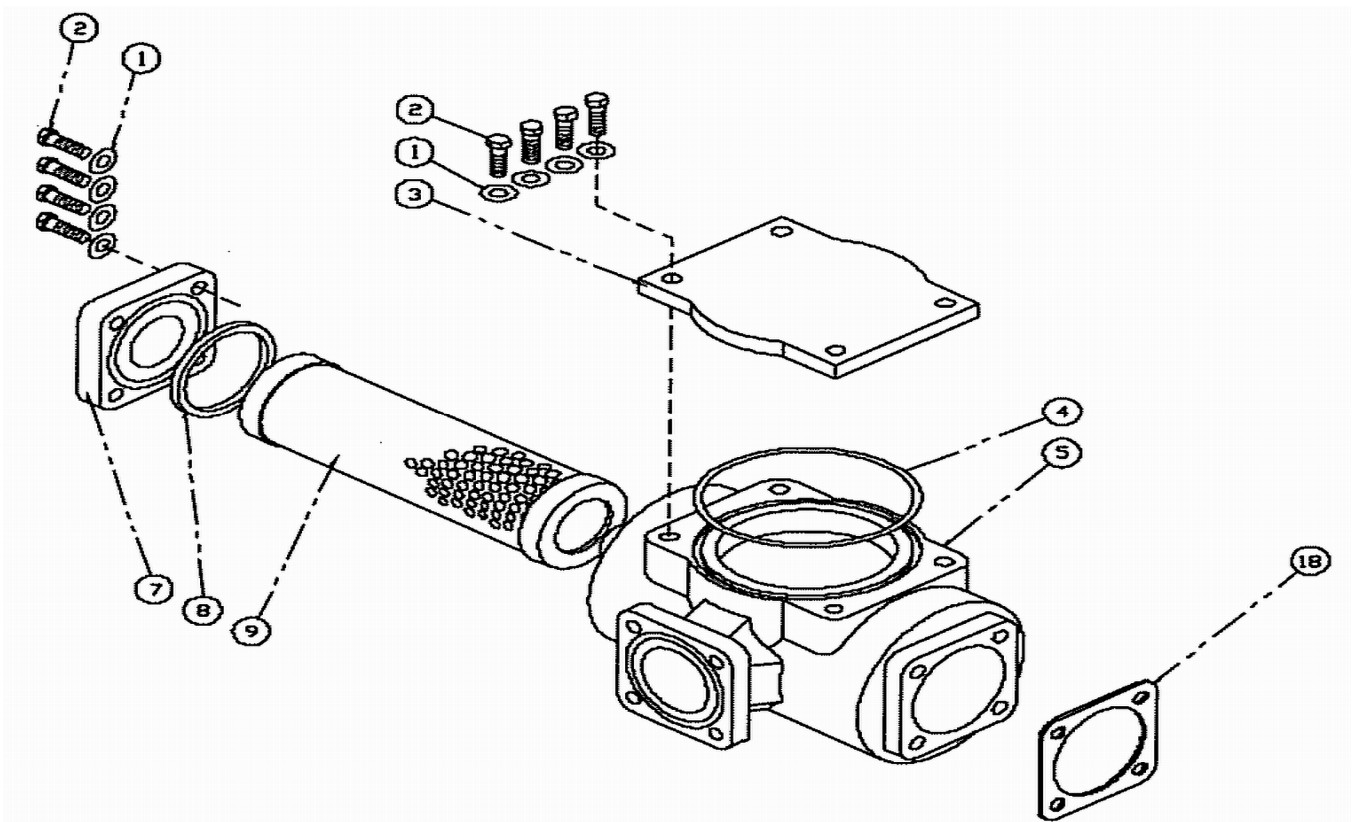

<u>Item</u>	<u>Description</u>	<u>Qty</u>	<u>Part Number</u>
1	Flat Washer	8	AE015
2	Cap Screw	8	AE016
3	Strainer Cover (optional with no A/E)	1	AE041
4	Top Seal O'Ring	1	AE009
5	Strainer Housing	1	AE021
7	Basket Cover	1	AE018
8	Seal Ring	1	AE003
9	Strainer Basket	1	AE040
18	Flange Gasket	1	AE022



# macnaught warranty

1. Macnaught Pty Ltd (“Macnaught”) warrants that all products manufactured by Macnaught and/or supplied by Macnaught under the “Macnaught” brand, excluding M-SERIES, MEC-SERIES and WM-SERIES positive displacement meters (“Meters”) and components subject to wear, will be free from any defects caused by faulty materials or workmanship (“Warranty”) for a period of 5 years from the date of purchase of the product.
2. For products (excluding Meters) which carry the “Macnaughtdesign” endorsement, an additional Warranty period of 5 years applies to all mechanical components (excluding electronic and electrical components), giving a total Warranty period of 10 years.
3. For Meters, the Warranty period is 2 years from the date of purchase of that product.
4. For components contained in all products which are usually subject to wear from normal operation of the products (such as o-rings, seals, bushes, springs, hoses and batteries), the Warranty period is 12 months from the date of purchase of the relevant product.
5. For products and components which are not manufactured by Macnaught and are supplied by Macnaught under a brand name other than “Macnaught”, the Warranty period is the longer of 12 months from the date of purchase of the relevant product and the period of the manufacturer’s warranty.
6. The warranties contained in clauses 1, 2, 3, 4 and 5 above are conditional on the purchaser, during the relevant Warranty period:
  - A. delivering to Macnaught a detailed notice setting out full details of any defect in any product and details of the date and place of purchase (together with copies of purchase receipts and/or other supporting documents); and
  - B. at the purchaser’s own cost, returning the defective product to the nearest authorised Macnaught service centre.
7. Subject to compliance by the purchaser with clause 6, Macnaught shall, at its option, repair or replace any product or component found defective by its inspection by reason of faulty materials or workmanship of Macnaught.
8. This Warranty does not cover the failure of products, parts or components which, in the sole judgment of Macnaught, arises other than from faulty materials or workmanship of Macnaught, including misuse, abrasion, corrosion, negligence, accident, substitution of non-Macnaught parts, unauthorised modification, improper use, storage or handling, faulty installation or tampering by the purchaser or any third party.
9. If Macnaught’s inspection discloses no defect in material or workmanship, repair or replacement and return (at Macnaught’s sole option) will be made at customary charges, which will be advised to the purchaser.
10. Macnaught’s liability and the purchaser’s rights under this Warranty shall be limited to the repair or replacement of defective products or components and in particular, shall not extend to any direct, special, indirect or consequential damage or losses of any nature.
11. The foregoing Warranty supersedes, voids and is in lieu of all or any other warranties.

This Warranty does not form part of, nor does it constitute, a contract between Macnaught and the end-user or purchaser. It is additional to any warranty given by the seller of the products. This Warranty does not exclude, limit, restrict or modify the non-excludable rights or remedies conferred upon the end-user or purchaser, or the non-excludable duties or liabilities imposed on the seller or Macnaught, by Part V, Divisions 2, 2A and Part VA of the Trade Practices Act 1974 (Commonwealth) or other legislative provisions. Macnaught otherwise excludes, to the extent permitted by law, any rights conferred on the end-user or purchaser or duties or liabilities imposed upon Macnaught.



**Macnaught Pty Ltd**  
**PO Box 90 Arncliffe NSW 2205 Australia**  
**Telephone (02) 9567 0401**  
**Facsimile (02) 9597 7773**  
**Email: sales@macnaught.com.au**  
**Web: www.macnaught.com.au**