

GE068
0509
0002



## ELECTRIC DIESEL FUEL PUMP GEMB240A50-01 MINI BOWSER (240 Volt) INSTRUCTION MANUAL

### INTRODUCTION

Thank you for purchasing the Macnaught GEMB240A50 240 Volt Electric Mini Bowser.

The Macnaught Mini Bowser is supplied complete with built in Meter, Automatic Fuel Nozzle, 4m x 25mm I/D Fuel Resistant outlet hose.

Macnaught also have a complete range of retractable hose reels, fuel nozzles, electric or manual fuel pumps, air operated or manual oil pumps and a full range of greasing equipment available to suit all of your fluid handling requirements.

### GENERAL INFORMATION

This manual assists you in operating and maintaining your electric diesel pump. The information contained will help you ensure many years of dependable trouble free operation.

Please take a few moments to read through this manual before installing and operating your electric fuel pump. If you require further assistance please contact your local Macnaught distributor.

**Please read and retain this instruction manual to assist you in the operation and maintenance of this quality product.**

### IMPORTANT INFORMATION

#### WARNING

**Do not use this pump with Leaded or Unleaded Petrol.**

**Any additional wiring must be carried out by a licensed electrician.**

### DESCRIPTION

The Macnaught Electric Diesel Pump has been designed to reliably transfer diesel and kerosene. The pump has the added feature of a continuous duty cycle.

#### CAUTION

**Only use an automatic nozzle recommended by Macnaught, failure to do so may damage the pump and would void the pump warranty.**

### ASSEMBLY

#### PUMP INSTALATION



1) Securely position the pump to the desired location.

**Note: Ensure that the suction hose or suction tube has an inside diameter of 1-1/4" and is no longer than 2.7m long.**

2) Connect the 1-1/4" I/D suction hose or suction tube to the pump inlet.

**Note: Do not over tighten connections.**

3) We recommend a strainer assembly be used to the remaining end of the suction hose to prevent the possibility of foreign material entering the pump.

4) Insert the suction hose into the fuel tank.

5) Apply thread sealant to both threads of the delivery hose. Screw one end of the hose to the outlet thread on the meter and tighten.

**Note: Do not over tighten connections.**

6) Screw the dispensing nozzle to the remaining end of the hose assembly and tighten.

7) Place the auto nozzle into its holder on the Mini-Bowser.

8) Connect your Mini-Bowser to a 240volt power supply.

#### WARNING

**NOTE: Any additional wiring must be carried out by a licensed electrician.**

## PUMP PRIMING

1) The pump will prime with no fluid in the chamber to a height of 2.7 metres. If the height from the pump to the lowest fuel level is greater than 2.7 metres, we recommend that a non-return valve be fitted to the bottom of the suction hose.

2) If the suction height is too great, the pump may lose its prime if the nozzle is opened with the pump turned off.

3) The tank must be vented or the pump may not prime or may lose its prime due to a vacuum in the tank.

## OPERATING INSTRUCTIONS

1) Place the 3 pin plug on the pump into the nearest 240 volt power supply socket.

2) Lift the auto nozzle from the holder on the mini-bowser and place the nozzle spout into the fuel tank to be filled.

Note: The pump will automatically start when the auto nozzle is lifted from its holder on the mini-bowser.

3) Press and latch the trigger on the auto nozzle to dispense fuel. When the tank is full the auto nozzle will automatically release and fluid flow will stop.

4) After use, place the auto nozzle into the nozzle holder on the mini-bowser, this will automatically turn the pump off.

5) Switch off at the power point and remove the plug.

**DO NOT OPERATE PUMP DRY.**

## MAINTENANCE

**Note: The pump must be removed from the mini-bowser if any maintenance or repair is required.**

### **WARNING**

**Switch off and remove the 3 pin plug from the 240 volt power supply before carrying out any maintenance.**

**Do not under any circumstances put your fingers inside the pump with the electric power connected. Serious injury can occur.**

## PUMP REMOVAL FROM MINI-BOWSER

1) Turn off the pump and disconnect the 3 pin plug from the power supply before carrying out any maintenance.

2) Remove outlet hose, 90 deg elbow, the reset button and suction hose from the mini-bowser.

3) Remove the cover from the mini-bowser to access the pump unit.

4) Carefully unscrew nut holding the micro switch from inside the nozzle holder and withdraw the switch from the rear of the holder to enable pump removal.

5) Unscrew and remove the mounting bolts holding the pump to the mini-bowser housing and carefully remove the pump and meter assembly.

## BY PASS POPPET VALVE REPLACEMENT

**Switch off and remove the 3 pin plug from the 240 volt power supply before carrying out any maintenance.**

1) Remove the pump from the mini-bowser housing (refer to Pump removal from mini-bowser).

2) Unscrew and remove poppet valve cover screw (13).

3) Remove the, spring and poppet valve (10,11).

4) Inspect all components for any signs of wear or damage and replace if required.

5) Assembly is a reversal of the disassembly procedure.

## VANE REPLACEMENT

**Switch off and remove the 3 pin plug from the 240 volt power supply before carrying out any maintenance.**

1) Remove the pump from the mini-bowser housing (refer to Pump removal from mini-bowser).

2) Remove the 4 Allen screws (9) from the pump body, and remove the pump body (8) and o'ring (7).

3) Remove the rotor (5) and vanes (4) from the pump shaft.

**Note: Take note of the correct orientation of the vanes before removing the vanes (4) from the rotor (5).**

4) Inspect the vanes (4) for wear or damage and replace if required.

5) Assemble the rotor assembly (5) to the pump shaft and fit the vanes (4) into the slots in the rotor.

**Note: Ensure correct orientation of the vanes (3).**

6) Fit the o'ring (7) carefully into the o'ring groove on the pump body (8) then carefully position the pump body over the rotor assembly (5) and firmly tighten the 4 Allen screws (9).

**Note: Ensure the vanes (4) remain in position when fitting the pump body (8).**

7) Assembly is a reversal of the disassembly procedure.

## MAIN SEAL REPLACEMENT

**Switch off and remove the 3 pin plug from the 240 volt power supply before carrying out any maintenance.**

1) Remove the pump from the mini-bowser housing (refer to Pump removal from mini-bowser).

2) Remove the 4 Allen screws (9) from the pump body (8), then remove the pump body (8) and o'ring (7).

3) Remove the rotor and vanes and drive key (5,4,6).

4) Using the correct size star driver remove the 4 star bolts.

5) Take note of the exact position of the end cover plate, then carefully remove the cover plate from the motor shaft.

6) Carefully remove the first part of the seal assembly (1) from the front motor cover, then carefully remove the remaining half of the seal assembly by carefully withdrawing the seal from the motor shaft.

**Note:** Ensure the orientation of the main seal is correct when fitting new seal.

7) Assembly is a reversal of disassembly procedure.

### FUEL METER DESCRIPTION

The meter incorporated in this mini-bowser is a notating disc type, with mechanical register.

The meter has a wire mesh strainer included and is located inside the inlet flange connecting the meter to the pump.

### CLEAN METER STRAINER

**Switch off and remove the 3 pin plug from the 240 volt power supply before carrying out any maintenance.**

- 1) Remove the pump from the mini-bowser housing. (refer to Pump removal from mini-bowser).
- 2) Unscrew and remove the 2 nuts and bolts holding the meter to the pump.
- 3) Remove and clean the wire mesh strainer from the meter inlet.
- 4) Assembly is a reversal of the disassembly procedure.

### METER CALIBRATION

- 1) Remove the cover from the mini-bowser to access the calibration screw located on top of the meter.
- 2) Purge air from the system by dispensing fuel into a container until a full flow occurs, then close the auto nozzle to stop flow.

### PARTS DIAGRAM

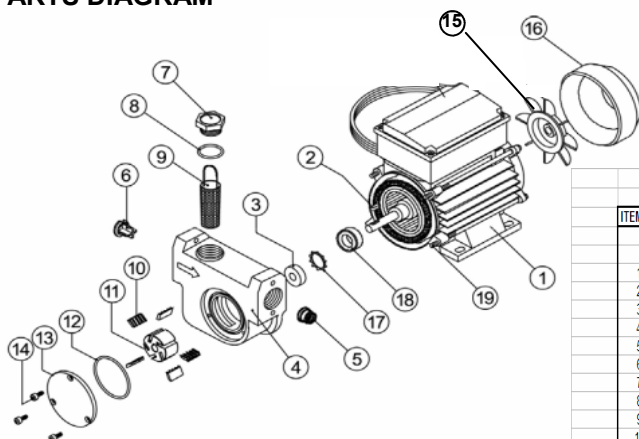

3) Reset the meter to zero by turning the reset knob clockwise.

4) Dispense fuel into a graduated calibration container to its specified quantity (ensure the container is placed on a level surface and a consistent flow rate is used). When topping off, a quick opening and quick closing method should be used until the mark is reached.

5) Compare the meter display to the quantity in the container. If the display does not match the quantity in the container, adjust the meter by using the following procedure:

- a) Remove the calibration cover screw located on top of the meter, this allows access the adjustment screw underneath.
- b) If the meter registered less than the quantity in the container turn the adjustment screw clockwise. Similarly if the meter registers more, turn the adjustment screw anticlockwise.

**Note:** Initially start by turning the adjustment screw a half turn and repeat steps (a) and (b) until the desired accuracy is reached.

6) Assembly is a reversal of the disassembly procedure.

### PARTS LIST

ITEM No	PART No	No OFF	ORDER FOR REPLACEMENT		DESCRIPTION
			PART OR SET	KIT REF.	
			GE-4K (KIT A)		SERVICE KIT
1	GE072	1	N/A		240V ELECTRIC MOTOR ASSEMBLY
2	GE073	1		A	DRIVE KEY 4 X 4 X 10
3	GE074	1		A	RETAINER
4	GE075	1		A	PUMP BODY
5	GE076	1		A	BYPASS SPRING
6	GE077	1		A	BYPASS VALVE
7	GE078	1		A	BYPASS PLUG
8	GE091	1		A	O-RING 30 X 3 NBR
9	GE079	1		A	STRAINER
10	GE081	5	GE081S	A	VANES
11	GE082	1			ROTOR
12	GE082	1		A	O-RING 51 X 3 NBR
13	GE083	1			PUMP BODY COVER
14	GE084	3			PUMP BODY COVER SCREWS M4 X 10
15	GE085	1	GE080S		FAN
16	GE086	1			FAN COVER
17	GE093	1		A	RETAINER O-RING
18	GE087	1		A	BEARING
19	GE088	4			SCREWS M6 X 126
20	GE089	1	GE089S		AUTOMATIC NOZZLE (NOT SHOWN)
21	GE090	1	GE090S		OUTLET HOSE ASSEMBLY (NOT SHOWN)

# TROUBLE SHOOTING GUIDE

TROUBLE	CAUSE	REMEDY
The motor runs but the pump will not prime.	<ul style="list-style-type: none"> <li>a) The valve (6) is damaged.</li> <li>b) There is dirt under the valve (6).</li> <li>c) The pump o'ring (12) is damaged.</li> <li>d) The fuel depth is too great to prime.</li> <li>e) The meter strainer is blocked.</li> <li>f) There is an air leak in the suction or suction tube connection.</li> <li>g) There is an air lock in the system.</li> </ul>	<ul style="list-style-type: none"> <li>a) Inspect valve (6) and replace if required.</li> <li>b) Inspect and clean the valve assembly (6).</li> <li>c) Replace the pump o'ring (12).</li> <li>d) Refer to priming instructions.</li> <li>e) Remove strainer from meter inlet connection and clean.</li> <li>f) Inspect the suction hose or suction tube connection, and re-seal if required.</li> <li>g) This may occur if a filter, meter or automatic nozzle is used. If this occurs, fill the pump and meter with fuel through the top of the pump.</li> </ul>
The pump output is low.	<ul style="list-style-type: none"> <li>a) The meter strainer or auto nozzle strainer is blocked.</li> <li>b) There is an air leak in the suction hose or suction tube connection.</li> <li>c) The tank is not vented.</li> <li>d) The motor is damaged.</li> <li>e) The suction hose, delivery hose, or nozzle is blocked.</li> </ul>	<ul style="list-style-type: none"> <li>a) Clean or replace the filter.</li> <li>b) Check suction hose or suction tube connection.</li> <li>c) The tank must be vented to atmosphere.</li> <li>d) Replace the pump unit.</li> <li>e) Inspect suction hose and delivery hose for any blockages.</li> </ul>
Pump Leaking	<ul style="list-style-type: none"> <li>a) Faulty seal (1).</li> <li>b) Faulty pump o'ring (12).</li> <li>c) Faulty o'ring (8).</li> </ul>	<ul style="list-style-type: none"> <li>a) Replace seal (17).</li> <li>b) Replace pump o'ring (12)</li> <li>c) Replace o'ring (8).</li> </ul>
Pump motor is overheating.	<ul style="list-style-type: none"> <li>a) The fluid is too viscous.</li> <li>b) Blocked meter strainer.</li> <li>c) Blocked suction hose, delivery hose or nozzle.</li> <li>d) Sticking vanes (10).</li> </ul>	<ul style="list-style-type: none"> <li>a) Refer to pump specifications</li> <li>b) Clean strainer.</li> <li>c) Inspect suction hose, delivery hose or nozzle for any blockages.</li> <li>d) Inspect and clean or replace if required.</li> </ul>
The switch will not turn on the pump.	<ul style="list-style-type: none"> <li>a) Power supply is not connected or switched on at the source</li> <li>b) Blown fuse.</li> <li>c) Defective switch.</li> <li>d) Damaged or defective motor.</li> </ul>	<ul style="list-style-type: none"> <li>a) Connect power to the pump.</li> <li>b) Replace fuse</li> <li>c) Check switch and replace if faulty.</li> <li>d) Check motor and replace pump unit if faulty.</li> </ul>
Meter is inaccurate.	<ul style="list-style-type: none"> <li>a) Re-calibrate meter (refer to meter Calibration procedure).</li> </ul>	



Macnaught Pty Ltd  
 PO Box 90 Arncliffe NSW 2205 Australia  
 Telephone (02) 9567 0401  
 Facsimile (02) 9597 7773  
 Email: sales@macnaught.com.au  
 Web: www.macnaught.com.au

## macnaught warranty

1. Macnaught Pty Ltd ("Macnaught") warrants that all products manufactured by Macnaught and/or supplied by Macnaught under the "Macnaught" brand, excluding M-Series positive displacement meters ("Meters") and components subject to wear, will be free from any defects caused by faulty materials or workmanship ("Warranty") for a period of 5 years from the date of purchase of the product.
  2. For products (excluding Meters) which carry the "Macnaughtdesign" endorsement, an additional Warranty period of 5 years applies to all mechanical components (excluding electronic and electrical components), giving a total Warranty period of 10 years.
  3. For Meters, the Warranty period is 12 months from the date of purchase of the product.
  4. For components contained in all products which are usually subject to wear from normal operation of the products (such as o-rings, seals, springs, hoses and batteries), the Warranty period is 12 months from the date of purchase of the relevant product.
  5. For products and components which are not manufactured by Macnaught and are supplied by Macnaught under a brand name other than "Macnaught", the Warranty period is the longer of 12 months from the date of purchase of the relevant product and the period of the manufacturer's warranty.
  6. The warranties contained in clauses 1, 2, 3, 4 and 5 above are conditional on the purchaser, during the relevant Warranty period:
    - a. delivering to Macnaught a detailed notice setting out full details of any defect in any product and details of the date and place of purchase (together with copies of purchase receipts and/or other supporting documents), and
    - b. at the purchaser's own cost, returning the defective product to the nearest authorised Macnaught service centre.
  7. Subject to compliance by the purchaser with clause 6, Macnaught shall, at its option, repair or replace any product or component found defective by its inspection by reason of faulty materials or workmanship of Macnaught.
  8. This Warranty does not cover the failure of products, parts or components which, in the sole judgment of the Macnaught, arises other than from faulty materials or workmanship of Macnaught, including misuse, abrasion, corrosion, negligence, accident, substitution of non-Macnaught parts, unauthorised modification, improper use, storage or handling, faulty installation or tampering by the purchaser or any third party.
  9. If Macnaught's inspection discloses no defect in material or workmanship, repair or replacement and return (at Macnaught's sole option) will be made at customary charges, which will be advised to the purchaser.
  10. Macnaught's liability and the purchaser's rights under this Warranty shall be limited to the repair or replacement of defective products or components and particular, shall not extend to any direct, special, indirect or consequential damage or losses of any other warranties.
  11. The foregoing Warranty supersedes, voids and is in lieu of any other warranties.
- This Warranty does not form part of, nor does it constitute, a contract between Macnaught and the end-user or purchaser. It is additional to any warranty given by the seller of the products. This Warranty does not exclude, limit, restrict or modify the non-excludable rights or remedies conferred upon the end-user or purchaser, or the non-excludable duties or liabilities imposed on the seller or Macnaught, by Part V, Division 2, 2A, and Part VA of the Trade Act 1974 (Commonwealth) or other rights conferred on the end-user or purchaser or duties or liabilities imposed upon Macnaught.