



macnaught

DIFFERENTIAL / SUM FLOWCOMPUTER

WITH ANALOG AND PULSE SIGNAL OUTPUTS



Features

- Calculates differential flow rate (consumption) total and accumulated total of flow A and B or the sum .
- Precautions for pulsating flows and very low consumption readings.
- 7 digit resettable total.
- 11 digit accumulated total.
- Large 17mm (0.67") digit selection for flow rate or total.
- Analog and pulse signal outputs.
- Very compact design for panel mount, wall mount or field mount applications.
- Operational temperature -30°C up to +80°C (-22°F up to 178°F).
- Rugged aluminum field mount enclosure IP67/NEMA4X.
- Intrinsically Safe
⊕ II 1 GD EEx ia IIB/IIC T4 T100°C.
- Full Modbus communication RS232/485/TTL.
- Loop or battery powered, 8 - 24V AC/DC or 115 - 230V AC power supply.
- Sensor supply 3.2 / 8.2 / 12 / 24V DC.

Signal output

- (0)4 - 20mA / 0 - 10V DC according to differential / sum flow rate.
- Scaled pulse output according to differential / sum accumulated total.
- Negative pulse value indication.

Signal input

Flow

- Reed-switch.
- NAMUR.
- NPN/PNP pulse.
- Sine wave (coil).
- Active pulse signals.
- (0)4 - 20mA.
- 0 - 10V DC.

Applications

- fuel consumption calculation for diesel engines on board of ships or locomotives. Sum function: where flows are split-up in two pipe-lines and total flow has to be calculated. More advanced model: 127.

General information

Introduction

The flowcomputer Model 116 has been developed to calculate differential or total volume. Typical applications are the measurement of fuel consumption or the calculation of total flow (sum) if - for costs reasons - two low cost flowmeters can be used instead of one expensive flowmeter. The usual difficulties encountered in such applications include: pulsating flows, very low consumption readings, vibration and high ambient temperatures. These are all well catered for in the design and operation of the 116.

Display

The display has large 17mm (0.67") and 8mm (0.31") digits which can be set to show flow rate and total. On-screen engineering units are easily configured from a comprehensive selection. The accumulated total can register up to 11 digits and is backed-up in EEPROM memory every minute.

Configuration

All configuration settings are accessed via a simple operator menu which can be pass-code protected. Each setting is clearly indicated with an alphanumeric description, therefore avoiding confusing abbreviations. Once familiar with one F-series product, you will be able to program all models in the series without a manual. All settings are safely stored in EEPROM memory in the event of sudden power loss.

Analog output signal

The calculated flow rate is re-transmitted with the (0)4 - 20mA or 0 - 10V DC output signal. The output signal is updated ten times per second with a filter function being available to smoothen out the signal if desired. The output value is user defined in relation to the flow rate, e.g. 4mA equals to 15L/Hr and 20mA equals to 2000L/Hr. The output signal can be passive, active or isolated where the passive output type will loop power the 116 as well.

Pulse output

The scaleable pulse output, reflects the count on the accumulated display. The pulse length is user defined and the maximum output frequency is 64Hz. The second output will be switched in case the total is counting down

(negative consumption). The output signal can be a passive NPN, active PNP or an isolated electro-mechanical relay.

Signal input

The 116 will accept most pulse and analog input signals for flow or mass flow measurement. The input signal type can be selected by the user in the configuration menu without having to adjust any sensitive mechanical dip-switches or jumpers.

Communication

All process data and settings can be read and modified manually or through the Modbus communication link (RS232 / RS485). Full Modbus functionality remains available for the Intrinsically Safe version (TTL).

Hazardous areas

For hazardous area applications, this model has been ATEX certified Intrinsically Safe $\text{Ex II 1 GD EEx ia IIB / IIC T4 T100}^\circ\text{C}$ with an allowed operational temperature of -30°C to $+70^\circ\text{C}$ (-22°F to $+158^\circ\text{F}$). A flame proof enclosure is also available with the rating $\text{Ex II 2 GD EEx d IIB T5}$.

Enclosures

There are three types of enclosures available: The GA Round Charcoal (Macnaught) version and the GC Round Red (MEC) version are available with 3 x 1/2" NPT cable gland entry thread or 2xM16 & 1xM20 cable gland entry thread. The third enclosure is the GB (Remote) enclosure which is available in GRP (Glassfiber Reinforced Polyamide) or Aluminum. For the cable gland entry available see page 6.

Overview application 116

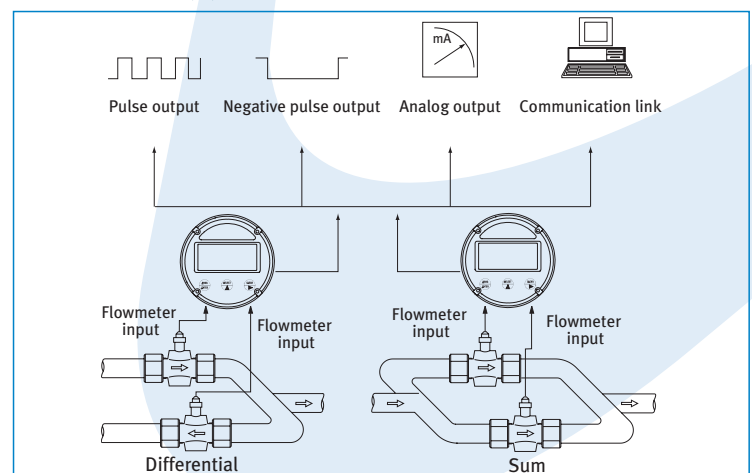

Dimensions enclosures

Aluminum round field / wall mount enclosure GA & GC

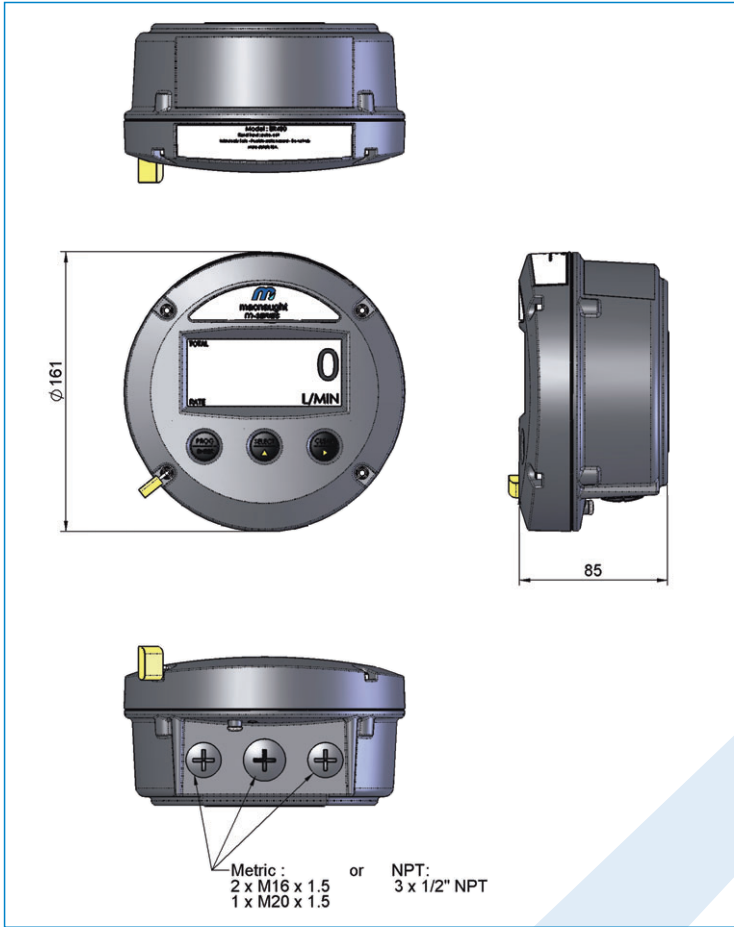

Aluminum & GRP field / wall mount enclosures GB

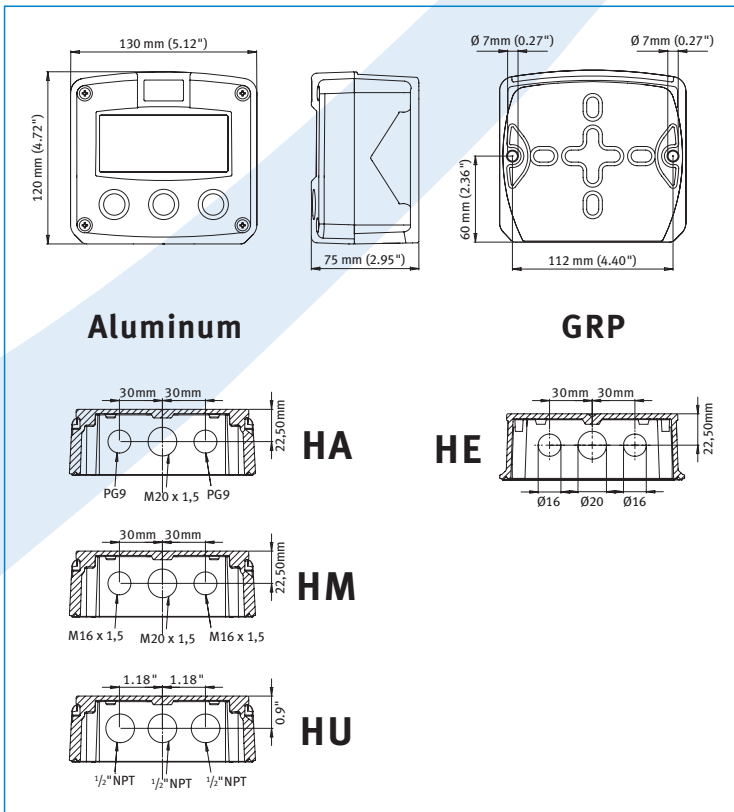

Terminal connections

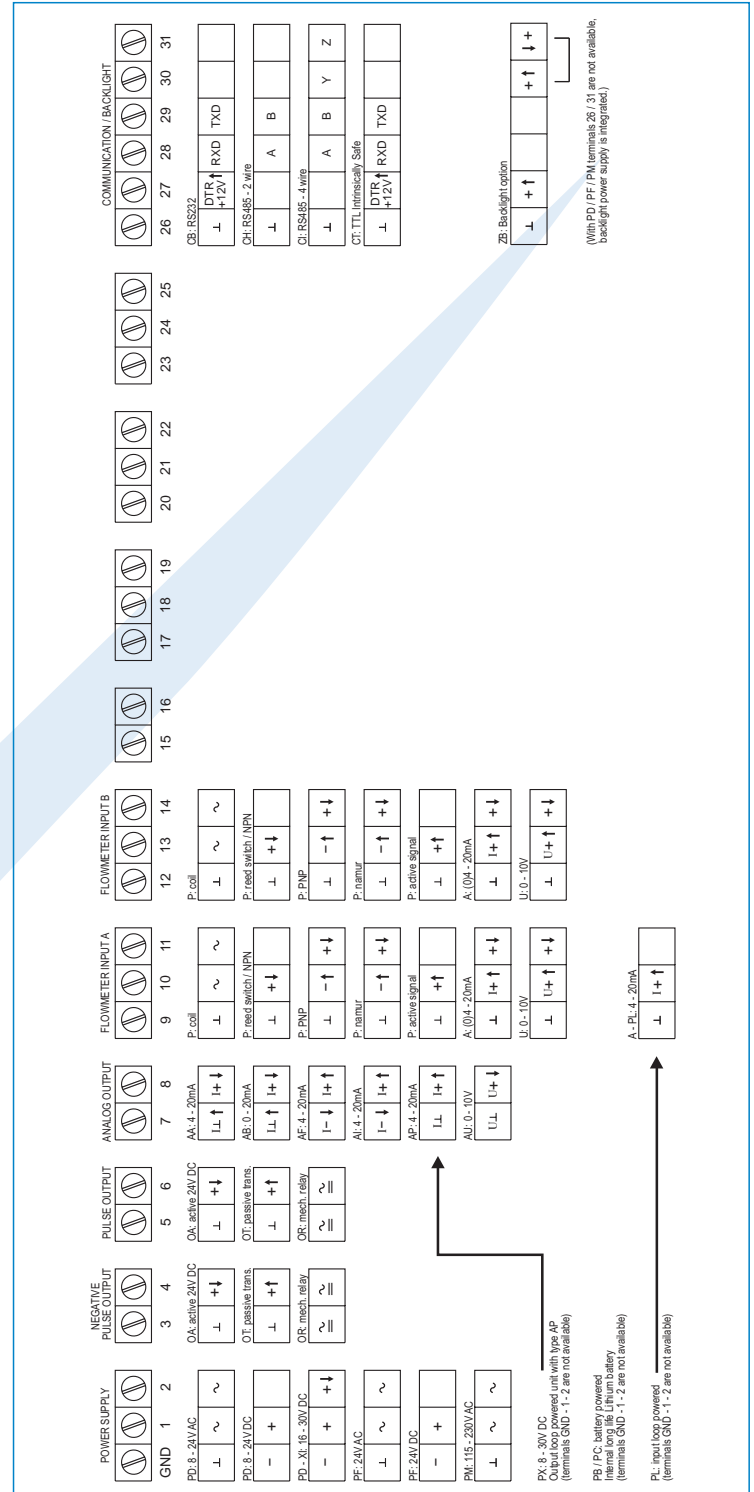

Display example - 90 x 40mm (3.5" x 1.6")

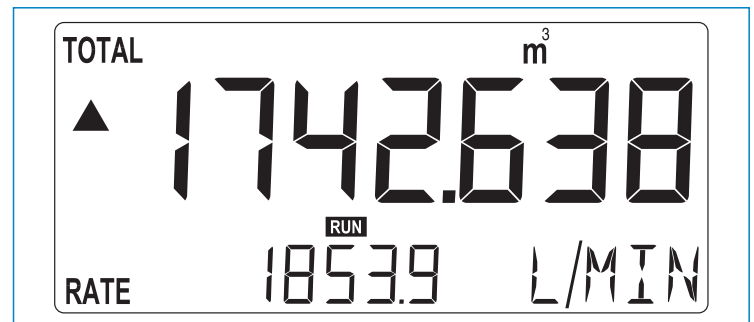

Typical wiring diagram 116-P-(AP)-CH-(OT)-PB

Typical wiring diagram 116-P-AP-CH-OT-PX

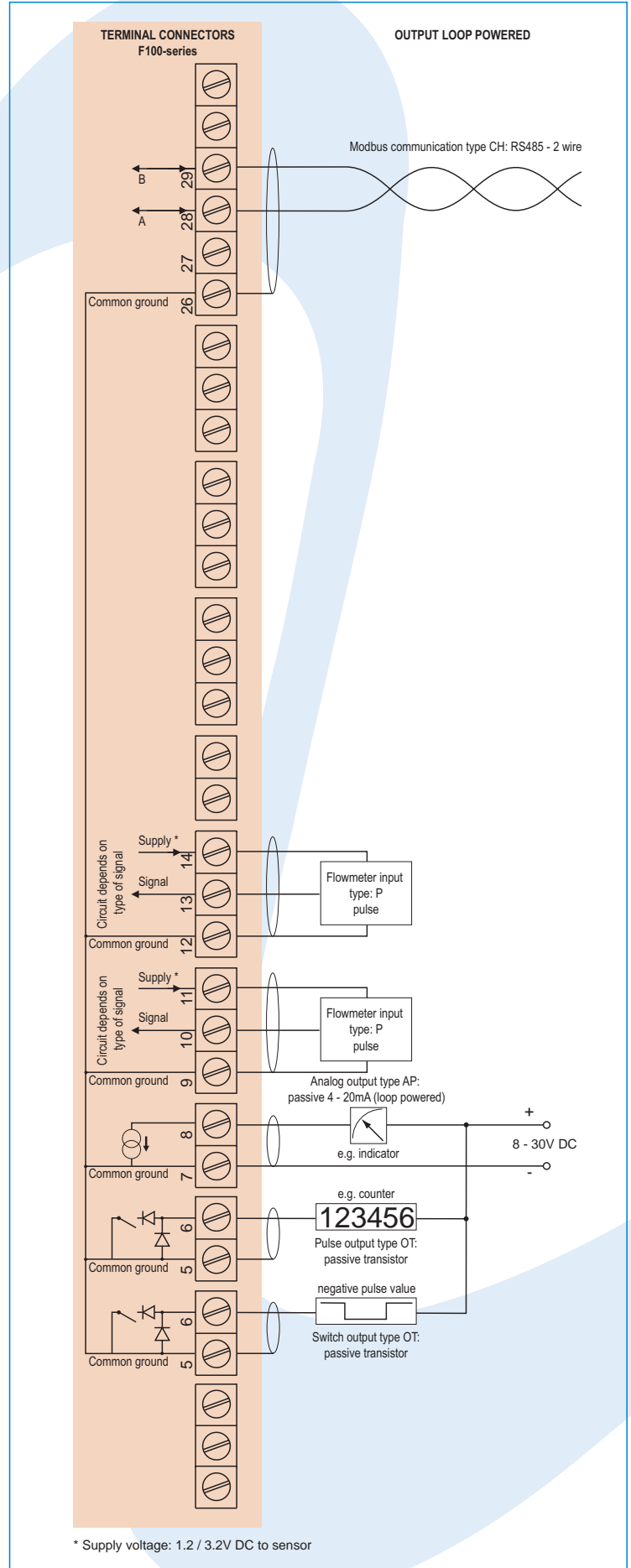
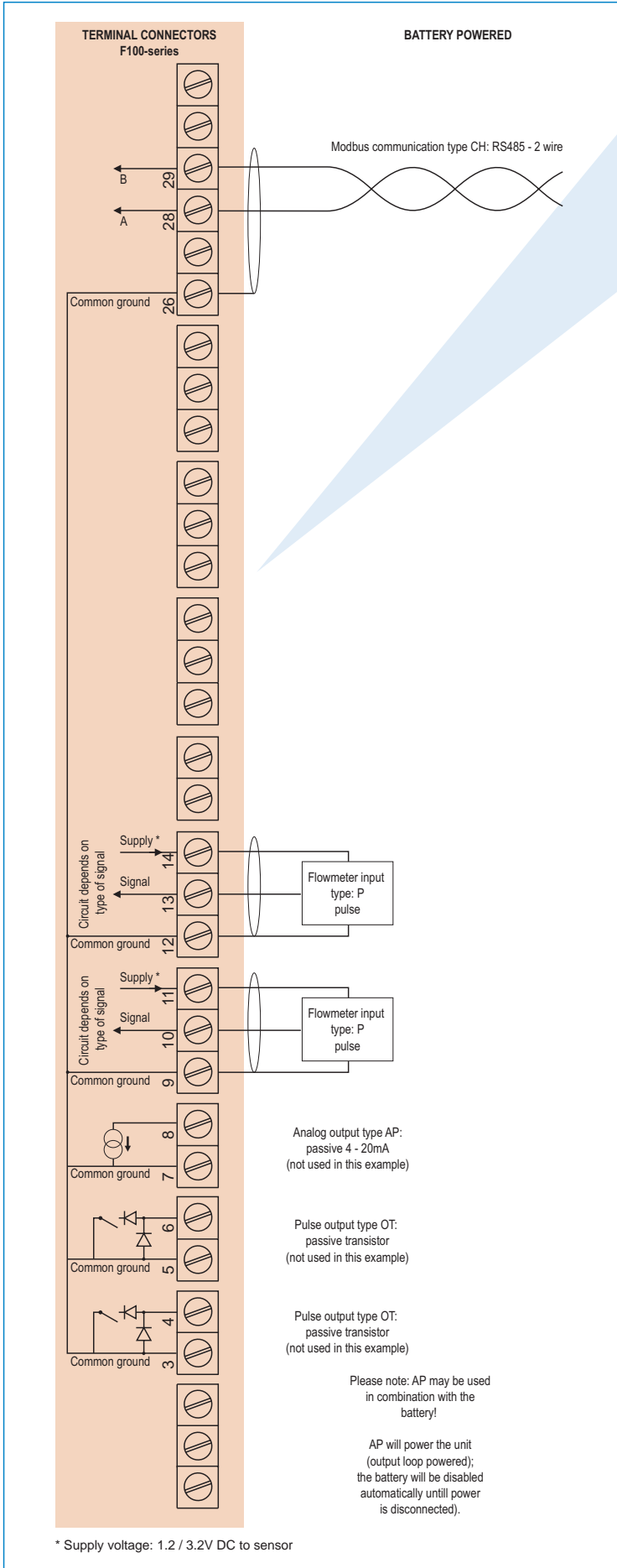

Typical wiring diagram 116-A-AA-CB-OA-PD

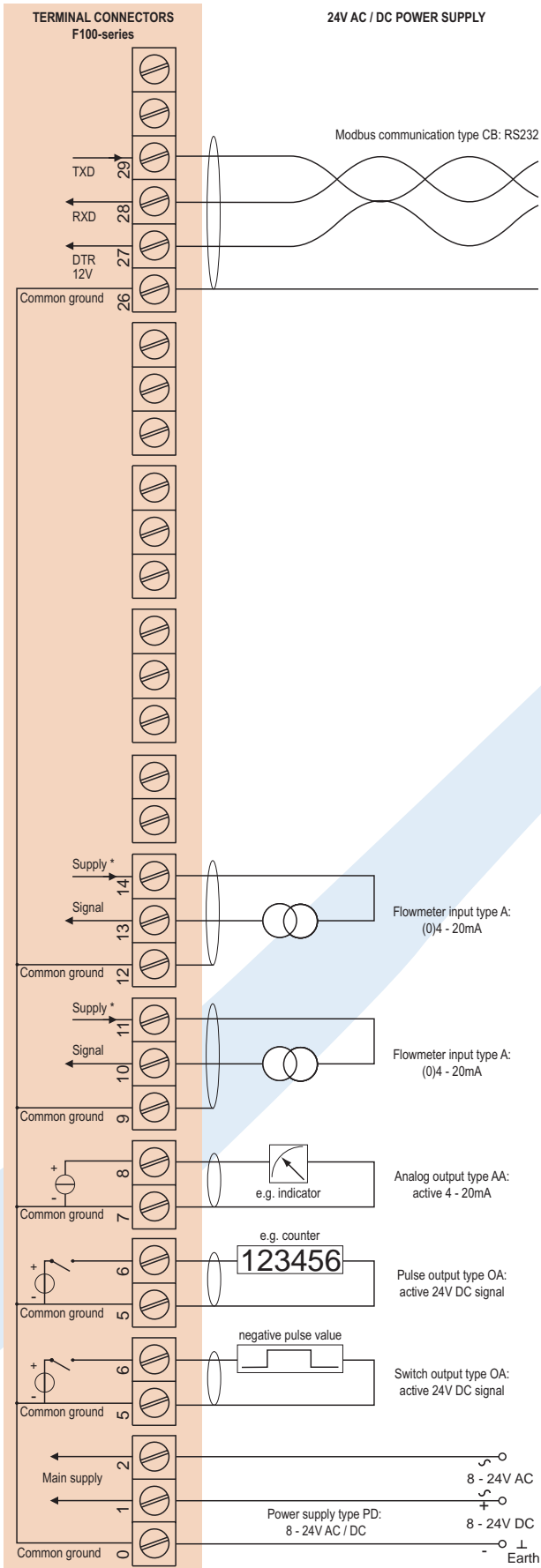

* Supply voltage: 3.2 / 8.2 / 12 / 24V DC to sensor

Typical wiring diagram 116-A-AI-CI-OR-PM

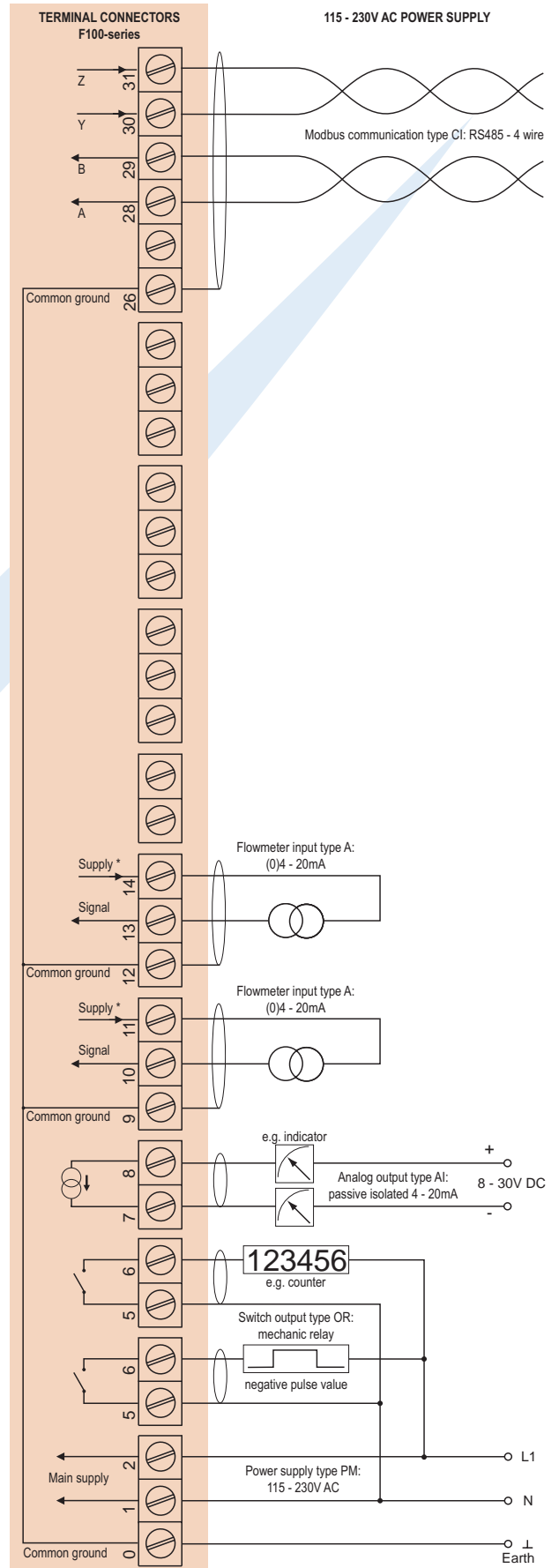

* Supply voltage: 3.2 / 8.2 / 12 / 24V DC to sensor

Technical specification

General

Display	
Type	High intensity reflective numeric and alphanumeric LCD, UV-resistant.
Dimensions	90 x 40mm (3.5" x 1.6").
Digits	Seven 17mm (0.67") and eleven 8mm (0.31") digits. Various symbols and measuring units.
Refresh rate	User definable: 8 times/sec. - 30 secs.
Option ZB	Transflective LCD with green LED backlight. Good readings in full sunlight and darkness.
Note ZB	Only available for safe area applications.

Operating temperature

Operational	-30°C to +80°C (-22°F to +178°F).
Intrinsically Safe	-30°C to +70°C (-22°F to +158°F).

Power requirements

Type PB	Long life Lithium battery - life-time depends upon settings and configuration - up to 5 years.
Type PC	Intrinsically Safe long life lithium battery - life-time depends upon settings and configuration - up to 5 years.
Type PD	8 - 24V AC / DC ± 10%. Power consumption max. 10 Watt. Intrinsically Safe: 16 - 30V DC; power consumption max. 0.75 Watt.
Type PF	24V AC / DC ± 10%. Power consumption max. 15 Watt.
Type PL	Input loop powered from sensor signal 4 - 20mA (type "A") - requires types AI or AF and OT.
Type PM	115 - 230V AC ± 10%. Power consumption max. 15 Watt.
Type PX	8 - 30V DC. Power consumption max. 0.5 Watt.
Type ZB	12 - 24V DC ± 10% or type PD / PF / PM. Power consumption max. 1 Watt.
Note PB/PF/PM	Not available Intrinsically Safe.
Note PF/PM	The total consumption of the sensors and outputs may not exceed 400mA @ 24V.
Note	For Intrinsically Safe applications, consult the safety values in the certificate.

Sensor excitation

Type PB/PC/PX	3.2V DC for pulse signals and 1.2V DC for coil pick-up.
Note	This is not a real sensor supply. Only suitable for sensors with a very low power consumption like coils (sine wave) and reed-switches.
Type PD	1.2 / 3.2 / 8.2 / 12 / 24V DC - max. 50mA @ 24V DC.
Type PD-XI	1.2 / 3.2 / 8.2V DC - max. 7mA @ 8.2V DC and mains power supply voltage (as connected to terminal 1).
Note	In case PD-XI and signal A or U: the sensor supply voltage is according to the power supply voltage connected to terminal 1. Also terminal 2 offers the same voltage.
Type PF / PM	1.2 / 3.2 / 8.2 / 12 / 24V DC - max. 400mA @ 24V DC.



Terminal connections

Type	Removable plug-in terminal strip. Wire max. 1.5mm ² and 2.5mm ² .
------	---

Data protection

Type	EEPROM backup of all settings. Backup of running totals every minute. Data retention at least 10 years.
Pass-code	Configuration settings can be pass-code protected.

Hazardous area

Intrinsically Safe	ATEX approval ref.:  II 1 GD EEx ia IIB/IIC T4 T100°C.
Type XI	Maximum ambient +70°C (158°F).
Explosion proof	ATEX approval ref.:  II 2 GD EEx d IIB T5.
Type XF	Dimensions of enclosure: 300 x 250 x 200mm (11.8" x 9.9" x 7.9") L x H x D.
Weight	appr. 15 Kg.

Environment

Electromagnetic compatibility	Compliant ref: EN 61326 (1997), EN 61010-1 (1993).
-------------------------------	--

Casing & cable gland entry

General

Window	Polycarbonate window.
Sealing	Silicone.
Control keys	Three industrial micro-switch keys. UV-resistant silicone keypad.

GB - Aluminum wall / field mount enclosures

General	Die-cast aluminum wall/field mount enclosure IP67 / NEMA 4X with 2-component UV-resistant coating.
Dimensions	130 x 120 x 75mm (5.12" x 4.72" x 2.95") - W x H x D.
Weight	1100 gr.
Type HA	Cable entry: 2 x PG9 and 1 x M20.
Type HM	Cable entry: 2 x M16 and 1 x M20.
Type HU	Cable entry: 3 x 1/2" NPT.

GB - GRP wall / field mount enclosures

General	GRP wall/field mount enclosure IP67 / NEMA 4X, UV-resistant and flame retardant.
Dimensions	130 x 120 x 75mm (5.12" x 4.72" x 2.95") - W x H x D.
Weight	600 gr.
Type HE	Cable entry: 2 x Ø 16mm and 1 x Ø 20mm.

GA & GC - Aluminum round wall / field mount enclosures

General	Die-cast aluminum wall/field mount enclosure IP67 / NEMA 4X with 2-component UV-resistant coating.
Dimensions	Ø 161 x 85mm (6.34" x 3.35") - Diam. x Depth.
Weight	1200 gr.
Colors	GA: Charcoal or GC: Red.
Type HM	Cable entry: 2 x M16 and 1 x M20.
Type HU	Cable entry: 3 x 1/2" NPT.

Signal inputs

Flowmeter	
Type P	Coil / sine wave (minimum 20mVpp or 80mVpp - sensitivity selectable), NPN/PNP, open collector, reed-switch, Namur, active pulse signals 8 - 12 and 24V DC.
Frequency	Minimum 0Hz - maximum 7kHz for total and flow rate. Maximum frequency depends on signal type and internal low-pass filter. E.g. reed switch with low-pass filter: max. frequency 120Hz.
K-Factor	0.000010 - 9,999,999 with variable decimal position.
Low-pass filter	Available for all pulse signals.
Option ZF	coil sensitivity 10mVpp.
Type A	(0)4 - 20mA. Analog input signal can be scaled to any desired range within 0 - 20mA.
Type U	0 - 10V DC. Analog input signal can be scaled to any desired range within 0 - 10V DC.
Accuracy	Resolution: 14 bit. Error < 0.025mA / \pm 0.125% FS. Low level cut-off programmable.
Span	0.000010 - 9,999,999 with variable decimal position.
Update time	Four times per second.
Voltage drop	Type A: 2.5V @ 20mA.
Load impedance	Type U: 3k Ω .
Relationship	Linear and square root calculation.
Note	For signal type A and U: external power to sensor is required; e.g. type PD.

Signal outputs

Analog output	
Function	Transmitting differential / sum flow rate.
Accuracy	10 bit. Error < 0.05%. Analog output signal can be scaled to any desired range.
Update time	Ten times per second.
Type AA	Active 4 - 20mA output (requires OA + PD, PF or PM).
Type AB	Active 0 - 20mA output (requires OA + PD, PF or PM).
Type AF	Passive floating 4 - 20mA output for Intrinsically Safe applications (requires PC, PL or PD).
Type AI	Passive galvanically isolated 4 - 20mA output - also available for battery powered models (requires PB, PD, PF, PL or PM).
Type AP	passive 4 - 20mA output - not isolated. Unit will be loop powered.
Type AU	Active 0 - 10V DC output (requires OA + PD, PF or PM).

Pulse output

Function	Pulse output according to differential or sum accumulated total and indication negative pulse output.
Frequency	Max. 64Hz. Pulse length user definable between 7.8 msec up to 2 seconds.
Type OA	Two active 24V DC transistor outputs (PNP); max. 50mA per output (requires AA + PD, PF or PM).
Type OR	Two electro-mechanical relay outputs (N.O.) - isolated; max. switch power 230V AC - 0.5A per relay (requires PF or PM).
Type OT	Two passive transistor outputs (NPN) - not isolated. Max. 50V DC - 300mA per output.

Communication option

Function	Reading display information, reading / writing all configuration settings.
Protocol	Modbus RTU.
Speed	1200 - 2400 - 4800 - 9600 baud.
Addressing	Maximum 255 addresses.
Type CB	RS232
Type CH	RS485 2-wire
Type CI	RS485 4-wire
Type CT	TTL Intrinsically Safe.

Operational

Operator functions

Displayed functions	<ul style="list-style-type: none"> Differential flow rate (consumption) or the sum of both flow rates. Differential / sum total and accumulated total. Total can be reset to zero by pressing the CLEAR-key twice.
---------------------	---

Total

Digits	7 digits.
Units	L, m ³ , GAL, USGAL, KG, lb, bbl, no unit.
Decimals	0 - 1 - 2 or 3.
Note	Total can be reset to zero.

Accumulated total

Digits	11 digits.
Units / decimals	According to selection for total.
Note	Can not be reset to zero.

Flow rate

Digits	7 digits.
Units	mL, L, m ³ , Gallons, KG, Ton, lb, bl, cf, RND, ft ³ , scf, Nm ³ , NL, ical - no units.
Decimals	0 - 1 - 2 or 3.
Time units	/sec - /min - /hr - /day.

Accessories

Mounting accessories

ACFo2	Stainless steel wall mounting kit.
ACFo5	Stainless steel pipe mounting kit (worm gear clamps not included).
ACFo6	Two stainless steel worm gear clamps \varnothing 44 - 56mm.
ACFo7	Two stainless steel worm gear clamps \varnothing 58 - 75mm.
ACFo8	Two stainless steel worm gear clamps \varnothing 77 - 95mm.
ACFo9	Two stainless steel worm gear clamps \varnothing 106 - 138mm.
ACF10	Customized Grevopal tagplates for ACFo2 and ACFo5, including stainless steel screws. Dimension: 95mm x 12.5mm (3.75" x 0.50").

Cable gland accessories

ACF20	For HA enclosure, includes O-rings.
ACF25	For HE enclosure, includes locknuts and O-rings.
ACF26	For HF enclosure, includes locknuts and O-rings.
ACF27	For HG enclosure, includes locknuts and O-rings.
ACF28	For HH enclosure, includes locknuts and O-rings.
ACF29	For HJ enclosure, includes locknuts and O-rings.
ACF32	For HM enclosure, includes O-rings.
ACF33	For HN enclosure, includes O-rings.
ACF34	For HO enclosure, includes O-rings.
ACF35	For HP enclosure, includes O-rings.
ACF39	For HT enclosure, includes O-rings.
ACF40	For HU enclosure, includes O-rings.

Ordering information

Standard configuration: GA-116-P-AP-CX-EX-HC-IX-OT-PX-TX-XX-ZX.

Ordering information: G _ - 116 _ - _ -A _ -C _ -EX -H _ -IX -O _ -P _ -TX -X _ -Z _

Enclosures - IP67 / NEMA4X

- GA Aluminum round enclosure, color Charcoal.
- GB Aluminum or GRP remote enclosure.
- GC Aluminum round enclosure, color Red.

Flowmeter input signal

- A (o)4 - 20mA input.
- P Pulse input: coil, npn, pnp, namur, reed-switch.
- U 0 - 10V DC input.

Analog output signal

- AA Active 4 - 20mA output - requires OA + PD, PF or PM.
- AB Active 0 - 20mA output - requires OA + PD, PF or PM.
- AF I.S. floating 4 - 20mA output - requires PC, PL or PD.
- AI Isolated 4 - 20mA output - requires PB, PD, PF, PL or PM.
- AP **Passive 4 - 20mA output, loop powered unit.**
- AU Active 0 - 10V DC output - requires OA + PD, PF or PM.

Communication

- CB Communication RS232 - Modbus RTU.
- CH Communication RS485 - 2wire - Modbus RTU.
- CI Communication RS485 - 4 wire - Modbus RTU.
- CT Intrinsically Safe TTL - Modbus RTU.
- CX **No communication.**

Flow equations

- EX **No flow equations.**

Cable entry for GB - GRP field / wall mount enclosures

- HE Cable entry: 2 x Ø 16mm & 1 x Ø 20mm.

Cable entry for GB - Aluminum field / wall mount enclosures

- HA Cable entry: 2 x PG9 + 1 x M20.
- HM Cable entry: 2 x M16 + 1 x M20.
- HU Cable entry: 3 x 1/2"NPT.

Cable entry for GA & GC - Aluminum round field / wall mount enclosures

- HM Cable entry: 2 x M16 + 1 x M20.
- HU Cable entry: 3 x 1/2"NPT.

Additional inputs

- IX **No additional input.**

Outputs

- OA Two active transistor outputs - requires AA, AB or AU and PD, PF or PM.
- OR Two mechanical relay outputs - requires PF or PM.
- OT **Two passive transistor outputs - standard configuration.**

Power supply

- PB Lithium battery powered.
- PC Lithium battery powered - Intrinsically Safe.
- PD 8 - 24V AC/DC + sensor supply - with XI: 16 - 30V DC.
- PF 24V AC/DC + sensor supply.
- PL Input loop powered from sensor signal type "A" - requires AI or AF and OT.
- PM 115 - 230V AC + sensor supply.
- PX **Basic power supply 8 - 30V DC (no real sensor supply). Unit requires external loop AP.**

Temperature input signal

- TX **No temperature input signal.**

Hazardous area

- XI Intrinsically Safe.
- XF EExd enclosure - 3 keys.
- XX **Safe area only.**

Other options

- ZB Backlight.
- ZF Coil input 10mVpp.
- ZX **No options.**

The bold marked text contains the standard configuration.

Available Intrinsically Safe.

Specifications are subject to change without notice.