

HG 55 OIL CONTROL GUN WITH ELECTRONIC PRESET

INSTRUCTION MANUAL



INTRODUCTION

Thank you for purchasing a Macnaught oil control gun complete with HG55 Electronic meter. Macnaught oil control guns have been designed to accurately dispense, measure and control oil flow. The control guns are suitable for use with engine oil, gear oil, automatic transmission fluid, anti-freeze/anti-boil and compatible fluids.

Macnaught also manufacture a complete range of ratio oil pumps and retractable oil hose reels to fulfil all your fluid handling needs.

Please read and retain this instruction manual to assist you in the operation and maintenance of this quality product.

Note: Batteries are not pre-fitted and are included separately inside the box. Please refer to "Battery Replacement" on page 3 for correct procedure.

GENERAL INFORMATION

This manual assists you in operating and maintaining your new oil control gun. The information contained will help you ensure many years of dependable performance and trouble free operation.

Please take a few moments to read through this manual before installing and operating your new oil control gun. If you experience problems with this product, refer to the trouble shooting sections of this manual. If you require further assistance please contact your local Macnaught distributor or authorised Macnaught service centre.

IMPORTANT INFORMATION



READ THIS INFORMATION CAREFULLY BEFORE USE.

Your safety is important to us. Please read and follow all safety instructions listed inside.

Some of these instructions alert you to the potential for personal injury. "Cautions" listed throughout this manual advise of potential practices or procedures which may cause damage to your equipment.

This oil control gun is not designed for in-line installation. Do not install with a shut-off valve on the outlet side of the meter. Such an installation could result in damage to the meter housing cover.

Ensure all operators have access to adequate instructions about safe operating and maintenance procedures.

Do not exceed the maximum working pressure of 10350 kpa / 1500 psi / 103 bar.



CAUTION

Do not hit the oil control gun if it fails to operate. Refer to "trouble shooting guide" or return the unit to your nearest authorised service centre.



Never point the nozzle at yourself or anyone else.

Never exceed the pressure rating of any component installed in the System.

Before each use check all hoses for signs of wear, leaks or loose fittings. Tighten all fluid connections regularly and replace weak or damaged hoses.

Before attempting any repairs or maintenance of this product firstly disconnect the air supply from the oil pump, then release the oil line pressure by pressing the lever on your oil control gun.

ASSEMBLY

Use Teflon tape (or suitable thread sealant) when connecting the oil control gun to an oil hose.

Outlet Nozzle.

The outlet nozzle can be fitted either "inline" (forward) or on the outlet port "pistol style" located under the gun.

The long outlet tube should be used for the "inline" option.

The short adaptor should be used (instead of the long outlet tube) when using the "pistol style" option.

Note: Use the threaded Plug supplied to seal the outlet port not in use.

OUTLET NOZZLE OPERATION

When fluid flows through the gun the outlet nozzle will automatically open. When the fluid flow stops the outlet nozzle will automatically shut.

HANDLE OPERATION

To latch the handle, press the lever, push the button and then release lever.

METER INTRODUCTION

Operating mode description

Sleep Mode: To minimise battery consumption the meter will revert to sleep mode if left idle for more than 2 minutes, and will automatically “power up” if the RESET, button is pressed or there is flow through the meter.

The Reset button can be used in two ways:

Press – Press and release the button.

Double click – Press and release the button twice quickly.

TOTALIZERS

There are three totalizers built in to your meter:

1) **Reset-able batch total:** Displays the current volume dispensed. To reset batch total press the reset button.

2) **Non reset-able accumulative total** is located below the batch total and displays the total volume the meter has dispensed.

3) **Reset-able accumulative total** is hidden from view and is used to track daily, weekly, or monthly usage.

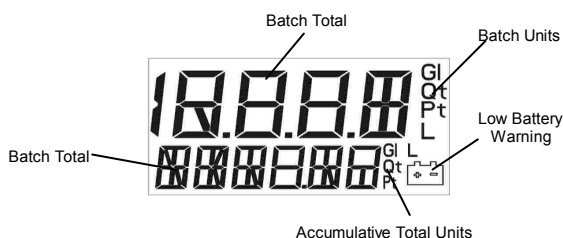

TO VIEW OR RESET ACCUMULATIVE TOTAL: RE T

1) Double click the Reset button (the display will enter the reset-able total area.

2) To reset the reset-able total, press and release the Reset button.

3) The display will return to manual mode after 5 seconds.

How to change the Units setting:

1) Press and hold down the Reset button for five seconds. (The unit segment will appear)

2) Press the Reset button to cycle through the unit options.

3) Stop at the required setting.

Batch Total	Accumulative Total
Litre	Litre
Pint	Gallon
Quart	Gallon
Gallon	Gallon

4) To store the selected units, press and hold down the Reset button for five seconds until the batch and accumulative totals appear. If the reset button is not held down for 5 seconds, the original settings will be restored.

Low Battery

The battery segment will flash when the battery is low and needs replacing.

Important: When the battery segment starts flashing replace the battery as soon as possible, use only Alkaline AA batteries.

Battery replacement

1) Remove the protective rubber boot.

2) Remove the battery cover screw located near the Inline (forward) outlet port and remove the battery cover.

3) Replace the two AA Alkaline batteries, note the battery direction label inside the housing.

4) Inspect the battery cover seal for damage and replace if necessary.

5) Replace battery cover and tighten screw.

Error signal

If an error is detected in the meter operation, the following error code will appear on the display.

Err1 – Sensor error

Err3 – Flowrate too high

Err4 – Calibration error

Err5 – Computer error

To reset the meter after an error signal press the Reset button.

MAINTENANCE



CAUTION

Before carrying out any maintenance disconnect the air supply to the pump and release the fluid pressure in the system by pressing the lever on the control gun.

Inspect your oil control gun daily for any signs of damage. Replace any damaged parts or components as required.

CONTROL HANDLE DISASSEMBLY

Use a clean bench to carry out maintenance.

A) Remove the oil hose from the control gun inlet swivel (26).

B) Unscrew and remove swivel (26) washer (24) and o’ring (25) from the control gun inlet. Clean or replace the strainer and o’ring.

Caution the swivel is under spring tension

C) Slide off the handle sleeve (23).

D) Remove valve spring (22), seal/valve body assembly (20,21) and plunger (19).

Lever and Valve removal

A) Using a 2.5mm allen key, remove the 2 handle screws (27).

B) Remove lever (29).

C) Remove the washer (18), “O”Ring (17), then push the valve cam (14) from the gun body (13), and remove “O”Ring (17).

CONTROL HANDLE REASSEMBLY

A) Clean and inspect all parts. Replace any suspect, worn or damaged components.

Note: Lightly lubricate the valve cam before assembly.

B) Place “O”Ring (17) onto valve cam (14).

Note: The cut out section in the middle of the valve cam (14) must face the inlet swivel (26).

- C) Replace the valve cam (14) into the body (13).
Note the orientation shown on the assembly drawing.
Fit the second "O"Ring (17) and washer (18).
- D) Slide lever assembly (29) into position and replace the two Allen screws (27). (Use Loctite or similar sealant).
- E) Replace plunger (19).
- Note:** The end hole in the plunger must face the meter.
- F) Assemble the seal/valve body (20, 21), and spring (22) and replace into the gun body.

- Note:** Install the spring, small end first.
- G) Replace handle sleeve (23).
- H) Replace washer (24), o'ring (25) swivel assembly (26), and screw firmly into place (Use Loctite or similar sealant).
- Note:** After assembly ensure the handle latch is operating correctly.

METER DISASSEMBLY

- 1) Unscrew the swivel assembly (26) two complete turns to allow easy disassembly and assembly of the meter and remove boot (1).
 - 2) Remove battery cover screw (3), the battery cover (5) and batteries (7).
 - 3) Remove the three Phillips screws (9) and the calibration port screw (16) from the underside of the meter.
 - 4) Carefully remove the computer module (2) from the module housing (8).
- Note:** The computer module is non repairable and will need to be replaced if damaged.
- 5) Remove the four Allen screws (15) from the underside of the meter and remove the module housing (8).
 - 6) Remove the rotors (11) and the body 'o' ring (12).

METER REASSEMBLY

- 1) Clean and inspect all parts. Replace any suspect, worn or damaged components.
- 2) Replace rotors (11) (Refer to Fig 1).

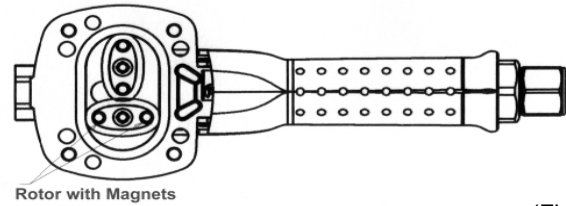

(Fig 1)

- Note:** Ensure the rotor with the magnets is assembled with the magnets facing up and positioned on the correct side of the meter. Both rotors must also be positioned at 90deg to each other (Refer Fig 1).
- 3) Replace the gun body 'o'ring (12).
 - 4) Carefully position the module housing (8) on top of the gun body (13), replace and tighten the four Allen screws (15).
 - 5) Ensure the handle latch is working correctly.
 - 6) Test the oil control gun for correct operation.
 - 7) Replace the computer module (2).
 - 8) Replace and tighten the three Phillips head screws (9) and calibration port screw (16).
 - 9) Replace the two AA Alkaline batteries (7). (use the directions on the label found inside the battery housing for correct battery orientation).
 - 10) Replace battery cover assembly (4,5,6) and tighten the screw (3).
 - 11) Firmly tighten the swivel assembly (26).
 - 12) Replace the boot (1).
 - 13) Test oil control gun for correct operation.

TROUBLE SHOOTING GUIDE

TROUBLE	CAUSE	REMEDY
No fluid passing through the meter	a) Blocked strainer	a) Clean or replace strainer
	b) Dirt particles jamming the rotors	b) Dismantle meter assembly and clean (refer to meter disassembly)
	c) Damaged plunger seal	c) Replace damaged plunger seal
The meter is not registering fluid output	a) Flat battery	a) Replace battery
	b) No signal from the magnets	b) Check magnets and replace rotors if required
	c) Damaged computer module (reed switch unit)	c) Replace computer module
Meter display reads Err 1	Sensor error	Press the reset button to reset the computer. (If the error repeats, check the magnets in the rotor)
Meter display reads Err 3	Flow rate to high	Adjust the flow rate to 1-30 l/mim (0.26-8 US gal/min) Eliminate air from the system
Meter display reads Err 4	Calibration error	Press the reset button to reset the computer
Meter display reads Err 5	Computer error	Press the reset button to reset the computer
		Note: Always press the reset button to reset the computer
Constant oil leak from the nozzle	Damaged plunger seal (20)	Replace plunger seal (check for damage)
Intermittent drip from the nozzle	Dirt in the nozzle (36)	Remove the nozzle and blow out any dirt particles, replace if necessary.
Oil leak from the lever assembly area	Damaged o' rings (17)	Replace damaged o' rings
Oil leak from between the body casting and the computer module casting	Damaged o' rings (12)	Replace damaged o' ring
Low flow rate	Blocked strainer (32)	Replace strainer
Oil leaking from the swivel inlet	Damaged o'ring or swivel	Replace swivel

SPARE PARTS DIAGRAM

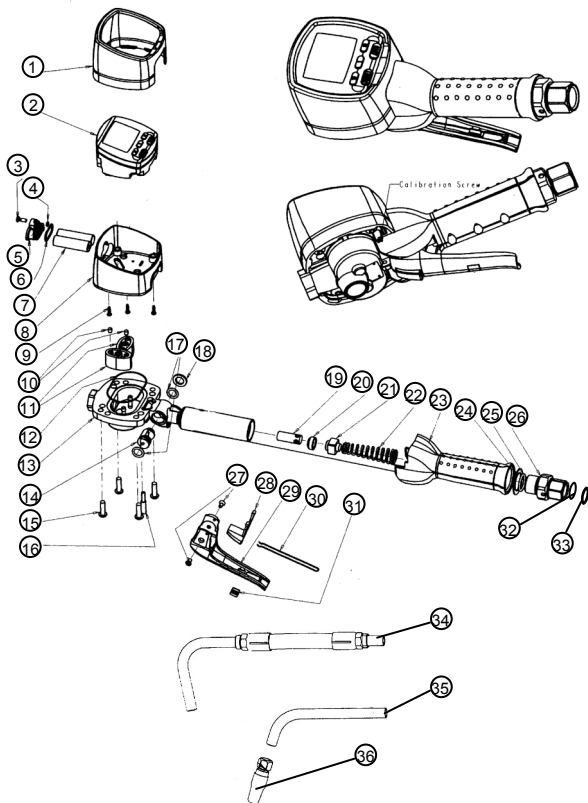

- * ORDER HG511s for Outlet Adapter Set (not Shown)
- * ORDER HGNZL for a Automatic non Drip nozzle (36)
- * ORDER HGREX for a Rigid Tube Extension (35) incl. outlet adapter set (not shown).
- * ORDER HGFNZ for a Flexible Extension assembly, incl. flexible extension (34), non drip nozzle (36) and adaptor (not shown).

SPARE PARTS LIST

ITEM	DESCRIPTION	OVERHAUL KIT	SPARE PARTS KIT
1	BOOT - VARIOUS COLOURS		HG381BKS / CS4E
2	ELECTRONIC MODULE		HG369AS
3	BATTERY COVER SCREW	HG50-1K	HG390AS
4	O-RING	HG50-1K	HG390AS
5	BATTERY COVER		HG390AS
6	BATTERY COVER INSERT	HG50-1K	HG390AS
7	AA ALKALINE BATTERIES		HG309S
8	MODULE HOUSING		HG380S
9	SCREW	HG50-1K	
10	MAGNET		HG005S
11	OVAL GEAR SET		HG005S
12	O-RING	HG50-1K	HG005S
13	GUN BODY		HG003S
14	VALVE CAM	HG50-1K/HG031-1K	
15	SCREW	HG50-1K	
16	CALIBRATION SCREW	HG50-1K	HG374S
17	O-RING	HG50-1K/HG031-1K	
18	WASHER	HG50-1K/HG031-1K	
19	PLUNGER		HG032S
20	SEAL	HG50-1K/HG031-1K	HG032S
21	VALVE BODY		HG032S
22	VALVE SPRING	HG50-1K/HG031-1K	HG032S
23	HANDLE SLEEVE		HG004BKS
24	WASHER	HG031-1K	
25	O-RING	HG031-1K	
26	SWIVEL ASSY	BSP OR NPT	HG040AS / HG043AS
27	SCREW	HG031-1K	
28	PUSH BUTTON		HG022S
29	LEVER	LATCH / NON LATCH	HG012AS / HG010AS
30	BUTTON SPRING		HG022S / HG023S
31	LEVER PLUG		HG022S / HG023S
32	FILTER MESH	HG50-1K/HG031-1K	
33	O-RING	HG50-1K/HG031-1K	

SPECIFICATIONS:

Accuracy:	+ - 0.5% (of Reading) (ISO100 @ 10 l/min)
Flow Range:	1-30 l/min (0.26 – 8 US gal/min)
Maximum Pressure:	103.50 BAR / 10350kPa / 1500 PSI
Pressure Loss:	1Bar/ 100kPa / 14.4PSI @ 12 l/min (3.2 US gal/min) with calibration fluid (6 Centipoise Viscosity) without extension.
Weight:	1.16kg (2.55lbs)
Swivel Inlet:	½" BSPT or ½" NPT
Outlet:	3/8" NPT
Operating Temperature:	-0 to +50 degrees Celsius (320 – 1220 degrees F)
Storage Temperature:	-10 to +60 degrees Celsius (14 – 140 degrees F)
Battery:	2 x 1.5Volt AA Batteries (Alkaline batteries are essential for HG60 version)
Wetted Parts:	Aluminium, Acetal, Steel, Nitrile Rubber
Fluid Compatibility:	Engine Oil, Diesel Oil, Automatic Transmission Fluid, Anti-freeze / Anti-Boil Mixture. (Maximum Viscosity SAE140)
Dimensions:	25.8cm (10inch) Long x 9.5 cm (3.7inch) High, 11cm (4.33inch) wide (Dimensions without extension)



Macnaught Pty Limited
ABN 66 000 075 785

41-49 Henderson Street
Turrella NSW 2205 Sydney Australia
Postal Address PO Box 90
Amcliffe NSW 2205 Sydney Australia

T: +61 2 9567 0401
F: +61 2 9597 7773
W: www.macnaught.com.au

For Warranty Terms and Conditions see macnaught.com.au
For a list of Australian Service Centres see macnaught.com.au