

MS489
0410
0006



# POSITIVE DISPLACEMENT FLOWMETERS

## M4 SERIES INSTRUCTION MANUAL

M4 Mechanical Meter • From Serial No. DXXXX



### TO THE OWNER

Please take a few minutes to read through this manual before installing and operating your meter. Always retain this manual for future reference.

If you have any problems with the meter, refer to the maintenance and trouble shooting sections of this manual.

This manual contains connection and operating instructions for meters with mechanical displays.

If you need further assistance, contact your local representative or distributor for advice.

This Flow Meter has incorporated the oval rotor principal into its design. This has proven to be a reliable and highly accurate method of measuring flow.

Exceptional repeatability and high accuracy over a wide range of fluid viscosities and flow rates are features of the oval rotor design. The low pressure drop and high pressure rating means oval rotor flow meters are suitable for both gravity and pump (in line) applications.

Flow meters are available in either Aluminium, Bronze or 316 Stainless Steel. Standard rotors are made from PPS (Polyphenylene Sulfide Resins).

Mechanical displays have a re-settable batch totaliser and non-re-settable accumulative totaliser.

## IMPORTANT INFORMATION



**PLEASE READ THIS INFORMATION CAREFULLY BEFORE USE!**

Before use, confirm the fluid to be used is compatible with the meter. Refer to Industry fluid compatibility charts or consult your local representative for advice.

**This meter will handle particle sizes up to 0.25mm/0.011”.**

To prevent damage from dirt or foreign matter it is recommended that a Y or basket type 60 mesh strainer be installed as close as possible to the inlet side of the meter. Contact your local representative for advice.

**Note:** When a strainer is installed it should be regularly inspected and cleaned. Failure to keep the strainer clean will dramatically effect flow meter performance.

**Note:** To prevent damage caused by air purge slowly fill the meter with fluid. To reduce pressure build up turn off the pump at the end of each day.

## OPERATING PRINCIPLE

When fluid passes through the meter the rotors turn, as shown below. The gear located on top of one of the rotors drives the mechanical registers gear train which then provides an accurate readout.

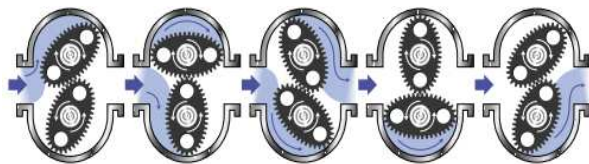

## INSTALLATION

1) It is recommended that when setting up pipe work for meter installations a bypass line be included in the design. This provides the facility for a meter to be removed for maintenance without interrupting production. (See Fig.1)

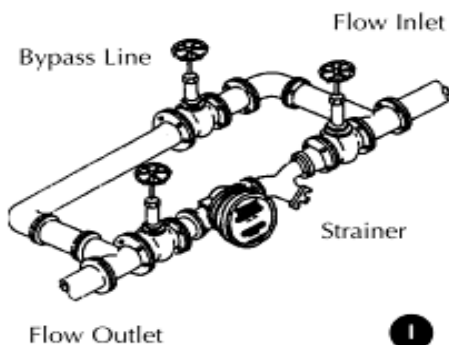

2) Use thread sealant on all pipe threads.

3) For pump applications ensure pipe work has the appropriate working pressure rating to match the pressure output of the pump.

The maximum working pressures are:  
1/2” aluminium or stainless steel series  
3450kPa/34.5Bar/500PSI.

4) Install a wire mesh strainer (Y or basket type) as close as possible to the inlet side of the meter.

5) Ensure that the meter is installed so that the flow of the liquid is in the direction of the arrows embossed on the meter body.

6) The meter can be installed in any orientation as long as the meter shafts are in a horizontal plane. (Refer to Fig.2 for correct installation)

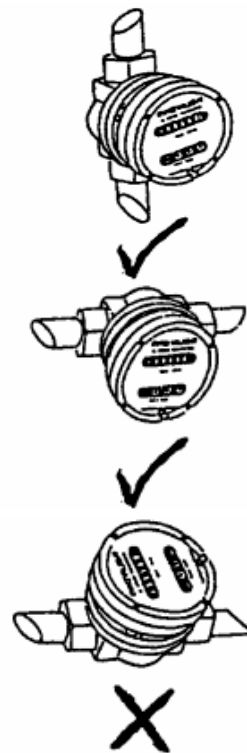

Do Not Install Meter This Way

2

**Note:** Incorrect installation can cause premature wear of meter components.

7) Do not over tighten meter connections.

8) It is important that after initial installation you fill the line slowly, high speed air purge could cause damage to the rotors.

9) Test the system for leaks.

10) Check the strainer for swarf or foreign material, after the first 200 litres check periodically, particularly if the flow rate decreases.

## SERVICE INSTRUCTIONS

### Disassembly

Ensure that the fluid supply to the meter is disconnected, and the line pressure is released before disassembly.

Refer to the exploded parts diagram and parts list, for item numbers.

- 1) Remove the four screws (Item 17) located on the face of the register. Then remove the face plate cover including register assembly.
- 2) Remove the four register mounting screws (Item 15) and remove the lower half of the register housing.
- 3) Remove the six cover plate screws (Item 12) and remove the cover plate (Item 11).
- 4) Remove the four meter cap screws (Item 5) and remove the meter cap (Item 4).
- 5) Remove rotors (Item 3).

### Reassembly

- 1) Clean all components before reassembly.
- 2) Before reassembling check the condition of the rotors (Item 3). Replace if necessary.
- 3) Replace the rotor (with the gear) on the short shaft in the housing then place the 2nd rotor onto the shaft so as the rotors are at 90dgr to each other. (Refer Fig.3).

Check rotor operation by turning either of the rotors.

If the rotors are not in mesh correctly or do not move freely remove one of the rotors and replace it correctly at 90dgr to the other rotor. Recheck the operation of the rotors.

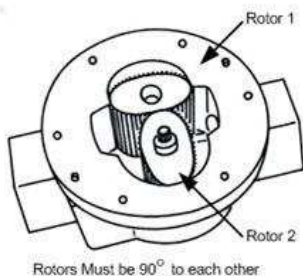

- 4) Inspect the gears (Item 6) in the meter cap (Item 4) for wear. (Replace if required, refer to spare parts on page 5).
- 5) Replace the o-ring (Item 2) into groove in the meter cap, if the o-ring has grown or is damaged in any way replace it with a new part.
- 6) Replace the meter cap making sure that the gear on the rotor meshing correctly with the gear in the meter cap (Item 4). Insert the cap head screws (Item 5) and tighten in a diagonal sequence 1, 4, 2, 3.
- 7) Inspect the bevel gear (Item 13), o-ring (Item 10) for wear or damage. (Replace faulty components if necessary).

- 8) Replacement of output shaft, bush and seal.

#### Disassembly of output shaft

- a. Remove the bevel gear.
- b. Remove the circlip and push out the output shaft assembly, including washer.
- c. Remove the seal.
- d. Carefully press out the output shaft bush (If required).

#### Assembly of output shaft

- a. Carefully press the new output shaft bush into place (Use Loctite Primer 7471, as per instructions, followed by sealant Loctite 680)
- b. Insert a new seal into the groove of the output shaft bush.
- c. Replace the output gear and washer and replace the circlip to lock the output gear shaft into place.
- d. Replace the bevel gear (Item 13) and tighten the grub screw onto flat face of shaft.

- 9) Place the o-ring (Item 10) into the groove in the meter cap (Item 4). (Replace the o-ring seal if required).

- 10) Place the cover plate onto the meter. Replace the cover plate screws and tighten the six cap head screws (Item 12) firmly.

- 11) Place the lower cover plate of the register into position. Replace the four screws (Item 15) and tighten.

- 12) Position the register correctly on top of the lower register cover. Replace the four screws (Item 17) and tighten.

- 13) Test the meter by turning the rotors with a finger or by applying low air pressure (No more than a good breath) to one end of the meter, before returning meter to the line.

# METER TROUBLE SHOOTING

TROUBLESHOOTING GUIDE		
TROUBLE	CAUSE	REMEDY
Fluid will not flow through the meter	a) Foreign matter blocking rotors b) Line strainer blocked c) Damaged rotors d) Meter connections over tightened e) Fluid is too viscous	a) Dismantle meter, clean rotors (strainer must be fitted in line) b) Clean strainer c) Replace rotors (Strainer must be fitted in line) d) Re-adjust connections e) See specifications for maximum viscosity
Reduced flow through the meter	a) Line strainer is partially blocked b) Fluid is too viscous	a) Clean strainer b) See specifications for maximum viscosity
Meter reading inaccurate	a) Fluid flowrate is too low or high b) Air in fluid c) Excess wear caused by incorrect installation	a) See specifications for min. and max. flowrates b) Bleed air from system c) Check meter body and rotors. Replace as required.
Fluid flows but no reading on meter	a) Bevel gear is loose on shaft b) Rotor drive gear is damaged c) Transmission gears damaged d) Register gears damaged	a) Tighten grub screws b) Replace rotor c) Replace gears d) Replace register assembly
Fluid leaks into register	a) Seal worn or damaged on the cover plate	a) Replace seal (Check seal compatibility with fluid)

## High viscosity fluids pressure loss and maximum flows

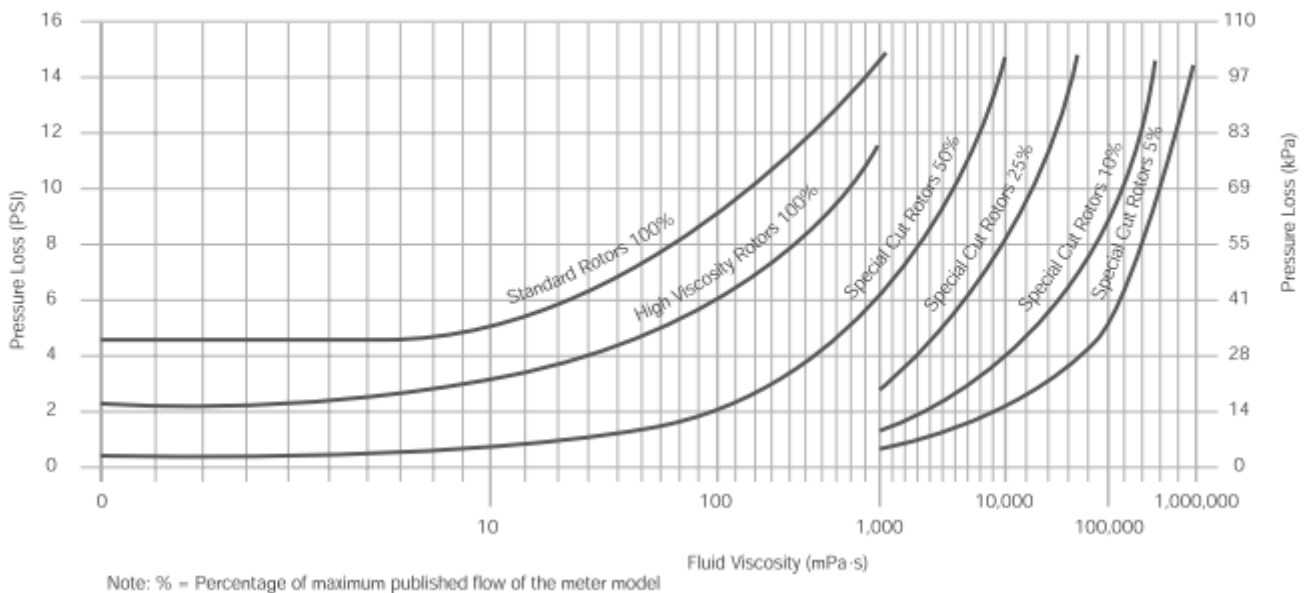

# METER PARTS LISTING

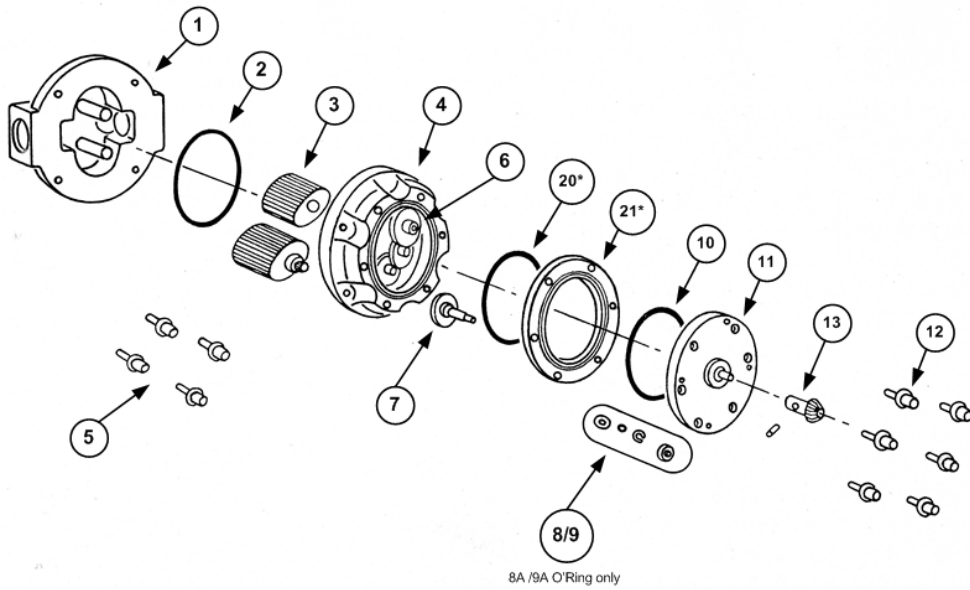

Item No.	No. Off	Rec. Parts	Part or Set (Order from this column only)	Part Description
1	1		MS298B	Meter Body 1/2" BSP (Aluminium)
1	1		MS298N	Meter Body 1/2" NPT (Aluminium)
<b>1</b>	<b>1</b>		<b>MS337B</b>	<b>Meter Body 1/2" BSP (Stainless Steel)</b>
<b>1</b>	<b>1</b>		<b>MS337N</b>	<b>Meter Body 1/2" NPT (Stainless Steel)</b>
2	1	X	BS145S	O-Ring (NBR)
2	1	X	BS145ES	O-Ring (EPDM)
2	1	X	BS145TES	O-Ring (Teflon)
2	1	X	BS145VS	O-Ring (Viton)
3	2	X	MS342MS	Rotors PPS (Polyphenylene Sulfide Resins)
3	2	X	MS342MTS	High Temperature Rotors (PPS)
3	2	X	MS342MHS	High Viscosity Rotors (PPS)
3	2	u	MS342MHTS	High Viscosity/High Temperature Rotors (PPS)
4	1		MS929S	Meter Cap Liters (Aluminium)
4	1		MS547S	Meter Cap US Gallons (Aluminium)
<b>4</b>	<b>1</b>		<b>MS928S</b>	<b>Meter Cap Liters (Stainless Steel)</b>
<b>4</b>	<b>1</b>		<b>MS546S</b>	<b>Meter Cap US Gallons (Stainless Steel)</b>
5	4		MS346S	Meter Cap Screws (Standard)
<b>5</b>	<b>4</b>		<b>MS350S</b>	<b>Meter Cap Screws (Stainless Steel)</b>
6	1		MS817S	Complete Gear Set – Liters
6	1		MS541S	Complete Gear Set – US Gallons
7	1		MS77S	Output Gear & Shaft Assembly
8	1	X	MS78S	Coverplate Seal/Bush Set (Standard)
8A	1	X	OR42CS	Solvent O-Ring (FFPM)
9	1		MS78C	Coverplate Seal/Bush Set (Solvent)
9A	1	u	E7-0075S	O-Ring (EPDM)
9A	1	u	V7-0075S	O-Ring (FKM)
10	1	u	BS145ES	O-Ring (EPDM)
10	1	u	BS145TES	O-Ring (FEP)
10	1	u	BS145VS	O-Ring (FKM)

## METER PARTS LISTING

Item No.	No. Off	Rec. Parts	Part or Set (Order from this column only)	Part Description
11	1		MS99S	Coverplate (Aluminium) includes bush
11	1		<b>MS99-1S</b>	<b>Coverplate (Stainless Steel) includes bush</b>
12	6		MS312S	Coverplate Screws – Litre model
12	6		<b>MS313S</b>	<b>Coverplate Screws (Stainless Steel) Litre Model</b>
12	6		MS419S	Coverplate Screws – US Gallon Model
12	6		<b>MS420S</b>	<b>Coverplate Screws (Stainless Steel) US Gallon Model</b>
13	1	X	MS83S	Bevel Gear Set
14	1	X	MS140S	Bottom Register Coverplate
15	4	X	MS111S	Mounting Screws
16	1	X	MS141M4S	Register Assembly with Coverplate - Litres
16	1	X	MS141US	Register Assembly with Coverplate – US Gallons
17	4	X	MS129S	Register Body Screws
20	1	X	BS145ES	O-Ring (EPDM)
20	1	X	BS145TES	O-Ring (FEP)
20	1	X	BS145VS	O-Ring (FKM)
21	1		MS423S	Spacer Ring (Aluminium) US Gallon Model Only
21	1		<b>MS423-1S</b>	<b>Spacer Ring (Stainless Steel) US Gallon Model Only</b>

Note: No parts diagram for the standard (M) register  
 Parts Listing for the industrial register (MR) consult instruction MK019

## METER DIMENSIONS

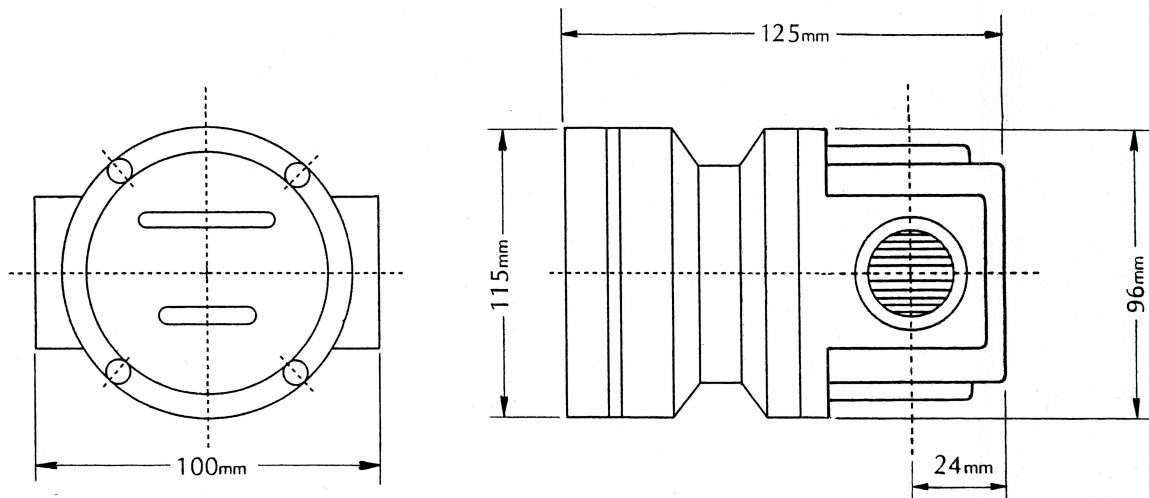

## METER SPECIFICATIONS

### Flow Ranges

(Litres per minute/US Gallons per minute)

**Above 5 Centipoise**

2 to 30/0.5 to 8

**Below 5 Centipoise**

3 to 25/0.8 to 6.6

**Accuracy of Reading**

+/- 1%

**Maximum Viscosity**

1000 Centipoise

**Maximum Operating Pressure**

3450 kPa/500 PSI/34.5 Bar

**Maximum Operating Temperature**

80 degrees C/176 degrees F

## macnaught warranty

1. Macnaught Pty Ltd ("Macnaught") warrants that all products manufactured by Macnaught and/or supplied by Macnaught under the "Macnaught" brand, excluding M-SERIES, MEC-SERIES and WM-SERIES positive displacement meters ("Meters") and components subject to wear, will be free from any defects caused by faulty materials or workmanship ("Warranty") for a period of 5 years from the date of purchase of the product.
2. For products (excluding Meters) which carry the "Macnaught design" endorsement, an additional Warranty period of 5 years applies to all mechanical components (excluding electronic and electrical components), giving a total Warranty period of 10 years.
3. For Meters, the Warranty period is 2 years from the date of purchase of that product.
4. For components contained in all products which are usually subject to wear from normal operation of the products (such as o-rings, seals, bushes, springs, hoses and batteries), the Warranty period is 12 months from the date of purchase of the relevant product.
5. For products and components which are not manufactured by Macnaught and are supplied by Macnaught under a brand name other than "Macnaught", the Warranty period is the longer of 12 months from the date of purchase of the relevant product and the period of the manufacturer's warranty.
6. The warranties contained in clauses 1, 2, 3, 4 and 5 above are conditional on the purchaser, during the relevant Warranty period:
  - A. delivering to Macnaught a detailed notice setting out full details of any defect in any product and details of the date and place of purchase (together with copies of purchase receipts and/or other supporting documents); and
  - B. at the purchaser's own cost, returning the defective product to the nearest authorised Macnaught service centre.
7. Subject to compliance by the purchaser with clause 6, Macnaught shall, at its option, repair or replace any product or component found defective by its inspection by reason of faulty materials or workmanship of Macnaught.
8. This Warranty does not cover the failure of products, parts or components which, in the sole judgment of Macnaught, arises other than from faulty materials or workmanship of Macnaught, including misuse, abrasion, corrosion, negligence, accident, substitution of non-Macnaught parts, unauthorised modification, improper use, storage or handling, faulty installation or tampering by the purchaser or any third party.
9. If Macnaught's inspection discloses no defect in material or workmanship, repair or replacement and return (at Macnaught's sole option) will be made at customary charges, which will be advised to the purchaser.
10. Macnaught's liability and the purchaser's rights under this Warranty shall be limited to the repair or replacement of defective products or components and in particular, shall not extend to any direct, special, indirect or consequential damage or losses of any nature.
11. The foregoing Warranty supersedes, voids and is in lieu of all or any other warranties.

This Warranty does not form part of, nor does it constitute, a contract between Macnaught and the end-user or purchaser. It is additional to any warranty given by the seller of the products. This Warranty does not exclude, limit, restrict or modify the non-excludable rights or remedies conferred upon the end-user or purchaser, or the non-excludable duties or liabilities imposed on the seller or Macnaught, by Part V, Divisions 2, 2A and Part VA of the Trade Practices Act 1974 (Commonwealth) or other legislative provisions. Macnaught otherwise excludes, to the extent permitted by law, any rights conferred on the end-user or purchaser or duties or liabilities imposed upon Macnaught.



Macnaught Pty Ltd  
PO Box 90 Arncliffe NSW 2205 Australia  
Telephone (02) 9567 0401  
Facsimile (02) 9597 7773  
Email: [sales@macnaught.com.au](mailto:sales@macnaught.com.au)  
Web: [www.macnaught.com.au](http://www.macnaught.com.au)