

MS1204
0808
0001

GA013PHRPB

GC013PHRPB

GB013PHxPB

**FLOWRATE MONITOR / TOTALIZER
WITH HIGH / LOW FLOWRATE ALARMS**

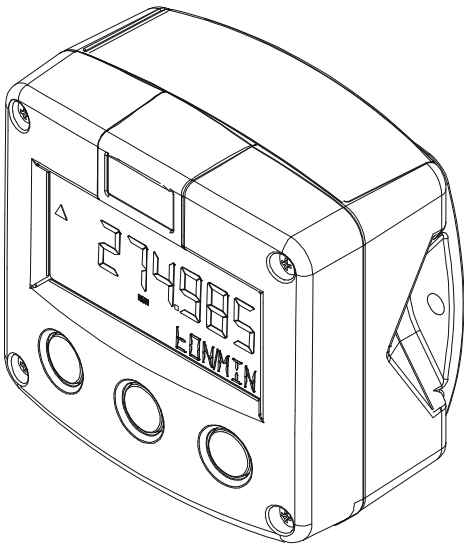

Signal input flowmeter: pulse, namur and coil.

Alarm output: one flowrate alarm.

Options: Intrinsically Safe.

SAFETY INSTRUCTIONS



- ***Any responsibility is lapsed if the instructions and procedures as described in this manual are not followed.***



- ***LIFE SUPPORT APPLICATIONS: The Gx013P is not designed for use in life support appliances, devices, or systems where malfunction of the product can reasonably be expected to result in a personal injury. Customers using or selling these products for use in such applications do so at their own risk and agree to fully indemnify the manufacturer and supplier for any damages resulting from such improper use or sale.***



- ***Electro static discharge does inflict irreparable damage to electronics! Before installing or opening the unit, the installer has to discharge himself by touching a well-grounded object.***



- ***This unit must be installed in accordance with the EMC guidelines (Electro Magnetic Compatibility).***



- ***Do connect a proper grounding to the aluminum casing as indicated if the Gx013P has been supplied with the 115-230V AC power-supply type PM. The green / yellow wire between the back-casing and removable terminal-block may never be removed.***



- ***Intrinsically Safe applications: follow the instructions as mentioned in Chapter 5.***

SAFETY RULES AND PRECAUTIONARY MEASURES

- The manufacturer accepts no responsibility whatsoever if the following safety rules and precautions instructions and the procedures as described in this manual are not followed.
- Modifications of the Gx013P implemented without preceding written consent from the manufacturer, will result in the immediate termination of product liability and warranty period.
- Installation, use, maintenance and servicing of this equipment must be carried out by authorized technicians.
- Check the mains voltage and information on the manufacturer's plate before installing the unit.
- Check all connections, settings and technical specifications of the various peripheral devices with the Gx013P supplied.
- Open the casing only if all leads are free of potential.
- Never touch the electronic components (ESD sensitivity).
- Never expose the system to heavier conditions than allowed according to the casing classification (see manufacture's plate and chapter 4.2.).
- If the operator detects errors or dangers, or disagrees with the safety precautions taken, then inform the owner or principal responsible.
- The local labor and safety laws and regulations must be adhered to.

ABOUT THE OPERATION MANUAL

This operation manual is divided into two main sections:

- The daily use of the unit is described in chapter 2 "Operation". These instructions are meant for users.
- The following chapters and appendices are exclusively meant for electricians/technicians. These provide a detailed description of all software settings and hardware installation guidance.

This operation manual describes the standard unit as well as most of the options available. For additional information, please contact your supplier.

A hazardous situation may occur if the Gx013P is not used for the purpose it was designed for or is used incorrectly. Please carefully note the information in this operating manual indicated by the pictograms:



A "**warning**" indicates actions or procedures which, if not performed correctly, may lead to personal injury, a safety hazard or damage of the Gx013P or connected instruments.



Caution !

A "**caution**" indicates actions or procedures which, if not performed correctly, may lead to personal injury or incorrect functioning of the Gx013P or connected instruments.



Note !

A "**note**" indicates actions or procedures which, if not performed correctly, may indirectly affect operation or may lead to an instrument response which is not planned.

Hardware version	:	FB03.03.xx
Software version	:	03.02.xx
Manual	:	MS531
© Copyright 2006	:	

Information in this manual is subject to change without prior notice. The manufacturer is not responsible for mistakes in this material or for incidental damage caused as a direct or indirect result of the delivery, performance or use of this material.

© All rights reserved. No parts of this publication may be reproduced or used in any form or by any means without written permission of your supplier.

CONTENTS MANUAL

Safety instructions	2
Safety rules and precautionary measures	2
About the operation manual	3
Contents manual.....	4
1. Introduction.....	5
1.1. System description of the Gx013P.....	5
2. Operational.....	6
2.1. General	6
2.2. Control panel.....	6
2.3. Operator information and functions.....	7
3. Configuration	9
3.1. Introduction	9
3.2. Programming SETUP-level.....	9
3.2.1. General	9
3.2.2. Overview functions SETUP level	12
3.2.3. Explanation of SETUP-functions.....	13
1 - Total.....	13
2 - Flowrate	14
3 - Alarm	15
4 - Display	15
5 - Power management.....	17
6 - Flowmeter	17
7 - Others	18
4. Installation	19
4.1. General directions	19
4.2. Installation / surrounding conditions.....	19
4.3. Dimensions- Enclosure	20
4.4. Installing the hardware.....	22
4.4.1. Introduction	22
4.4.2. Terminal connectors with power supply - <u>type : PB / PD / PX</u>	23
4.4.3. Terminal connectors with power supply - <u>type : PF / PM</u>	26
6. Maintenance.....	31
6.1. General directions	31
6.2. Repair.....	31
Appendix A: Technical specification	32
Appendix B: Problem solving.....	35
Index of this manual.....	36
List of figures in this manual	36

1. INTRODUCTION

1.1. SYSTEM DESCRIPTION OF THE GX013P

Functions and features

The flowrate / totalizer model Gx013P is a microprocessor driven instrument designed to display flowrate, total and accumulated total as well as the monitoring of the flowrate for high / low values. This product has been designed with a focus on:

- ultra-low power consumption to allow long-life battery powered applications (type PB / PC),
- intrinsic safety for use in hazardous applications (type XI),
- several mounting possibilities with GRP or aluminum enclosures for industrial surroundings,
- ability to process all types of flowmeter signals,
- transmitting possibilities with one configurable alarm output.

Flowmeter input

This manual describes the unit with a pulse type input from the flowmeter "-P version". Other versions are available to process (0)4-20mA or 0-10V flowmeter signals.

One flowmeter with a passive or active pulse, Namur or coil signal output can be connected to the Gx013P. To power the sensor, several options are available.

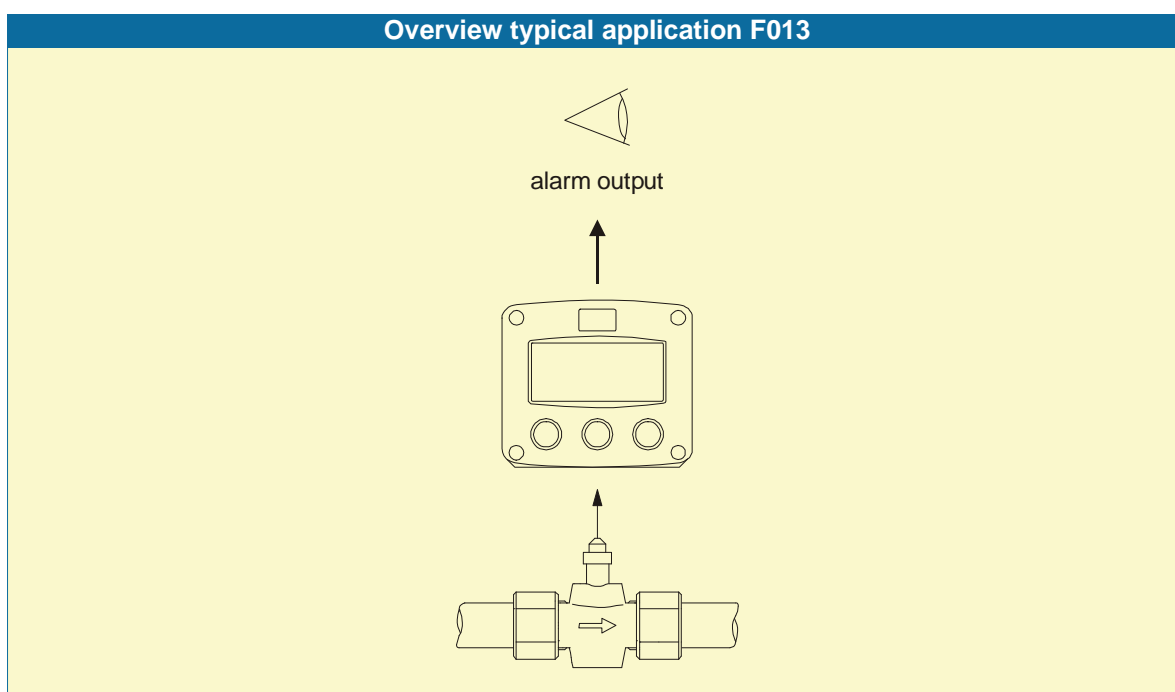

Fig. 1: Typical application for the Gx013P.

Configuration of the unit

The Gx013P has been designed to be implemented in many types of applications. For that reason, a SETUP-level is available to configure your Gx013P according to your specific requirements. It includes several important features, such as K-factors, measurement units, signal selection etc. All settings are stored in EEPROM memory and will not be lost in the event of power failure. To extend the battery-life time, please use of the power-management functions as described in chapter 3.2.3.

Display information

The unit has a large transfective LCD with all kinds of symbols and digits to display measuring units, status information, trend-indication and key-word messages.

Flowrate and totals can be displayed either with the small 8mm digits or with the 17mm digits.

A backup of the total and accumulated total in EEPROM memory is made every minute.

Options

The following options are available: intrinsic safety, mechanical relay or active outputs, power- and sensor-supply options, panel-mount, wall-mount and weather-proof enclosures, flame proof enclosure and LED backlight.

2. OPERATIONAL

2.1. GENERAL



- *The Gx013P may only be operated by personnel who are authorized and trained by the operator of the facility. All instructions in this manual are to be observed.*
- *Take careful notice of the " Safety rules, instructions and precautionary measures " in the front of this manual.*

This chapter describes the daily use of the Gx013P. This instruction is meant for users / operators.

2.2. CONTROL PANEL

The following keys are available:

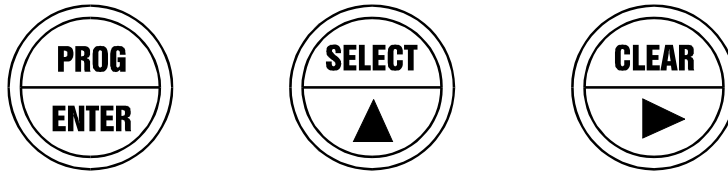

Fig. 2: Control Panel.

Functions of the keys



This key is used to program and save new values or settings.
It is also used to gain access to SETUP-level; please read chapter 3.



This key is used to SELECT accumulated total and flowrate alarm values.
The arrow-key ▲ is used to increase a value after PROG has been pressed or to configure the unit; please read chapter 3.



Press this key twice to CLEAR the value for total.
The arrow-key ► is used to select a digit after PROG has been pressed or to configure the unit; please read chapter 3.

2.3. OPERATOR INFORMATION AND FUNCTIONS

In general, the Gx013P will always act at Operator level. The information displayed is dependant upon the SETUP-settings. The signal generated by the connected flowmeter is measured by the Gx013P in the background, whichever screen refresh rate setting is chosen. After pressing a key, the display will be updated very quickly during a 30 second period, after which it will slow-down



again.

Fig. 3: Example of display information during process.

For the Operator, the following functions are available:

- **Display flowrate / total or flowrate**

This is the main display information of the Gx013P. After selecting any other information, it will always return to this main display automatically.

Total is displayed on the upper-line of the display and flowrate on the bottom line.

It is possible to display flowrate only with the large 17mm digits; in this instance press the SELECT-key to read the total.

When "-----" is shown, then the flowrate value is too high to be displayed. The arrows \blacktriangleleft \blacktriangleright indicate the increase/decrease of the flowrate trend.

- **Clear total**

The value for total can be re-initialized. To do so, press CLEAR twice. After pressing CLEAR once, the flashing text "PUSH CLEAR" is displayed. To avoid re-initialization at this stage, press another key than CLEAR or wait for 20 seconds.

Re-initialization of total DOES NOT influence the accumulated total.

- **Display accumulated total**

When the SELECT-key is pressed, total and accumulated total are displayed. The accumulated total cannot be re-initialized. The value will count up to 99,999,999,999.

The unit and number of decimals are displayed according to the configuration settings for total.

- **Programming the flowrate alarm values**



Note: This function might not be accessible due to a configuration setting.

When the SELECT-key is pressed a few times, following flowrate alarm values are displayed:

- low flowrate alarm: enter here 40 L/min for example,
- high flowrate alarm: enter here 200 L/min for example,

To change the alarm value, the following procedure must be executed:

- 1) press PROG: the word "PROGRAM" will flash or a pass code will be requested,
- 2) use \blacktriangleright to select the digits and \blacktriangle to increase that value,
- 3) confirm the new alarm value by pressing ENTER.



Fig. 4: Example of display information during programming minimum flowrate.

When data is altered but ENTER has not been pressed yet, then the alteration can still be cancelled by waiting for 20 seconds or by pressing ENTER during three seconds: the former value will be reinstated.

- **Flowrate alarm**

When the actual flowrate is outside the allowed range, an alarm message will be displayed indicating the type of alarm: "LO RATE", "HI RATE".

The alarm is terminated automatically as soon as the flowrate is within its range again.

- **Low-battery alarm**

When the battery voltage drops, it must be replaced. At first "low-battery" will flash, but as soon as it is displayed continuously, the battery **MUST** be replaced shortly after!

Only original batteries supplied by the manufacturer may be used, else the guarantee and liability will be terminated. The remaining lifetime after the first moment of indication is generally several days up to some weeks.



Fig. 5: Example of low-battery alarm.

- **Alarm 01-03**

When "alarm" is displayed, please consult Appendix B: problem solving.

3. CONFIGURATION

3.1. INTRODUCTION

This and the following chapters are exclusively meant for electricians and non-operators. In these, an extensive description of all software settings and hardware connections are provided.



- **Mounting, electrical installation, start-up and maintenance of the instrument may only be carried out by trained personnel authorized by the operator of the facility. Personnel must read and understand this Operating Manual before carrying out its instructions.**
- **The Gx013P may only be operated by personnel who are authorized and trained by the operator of the facility. All instructions in this manual are to be observed.**
- **Ensure that the measuring system is correctly wired up according to the wiring diagrams. The housing may only be opened by trained personnel.**
- **Take careful notice of the " Safety rules, instructions and precautionary measures " in the front of this manual.**

3.2. PROGRAMMING SETUP-LEVEL

3.2.1. GENERAL

Configuration of the Gx013P is done at SETUP-level. SETUP-level is reached by pressing the PROG/ENTER key for 7 seconds; at which time, both arrows \blacktriangleleft will be displayed. In order to return to the operator level, PROG will have to be pressed for three seconds. Alternatively, if no keys are pressed for 2 minutes, the unit will exit SETUP automatically. SETUP can be reached at all times while the Gx013P remains fully operational.



Note: A pass code may be required to enter SETUP. Without this pass code access to SETUP is denied.

To enter SETUP-level:

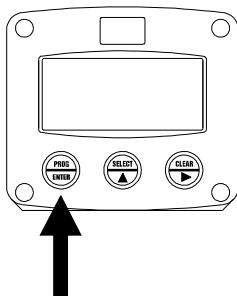

Press  for 7 seconds

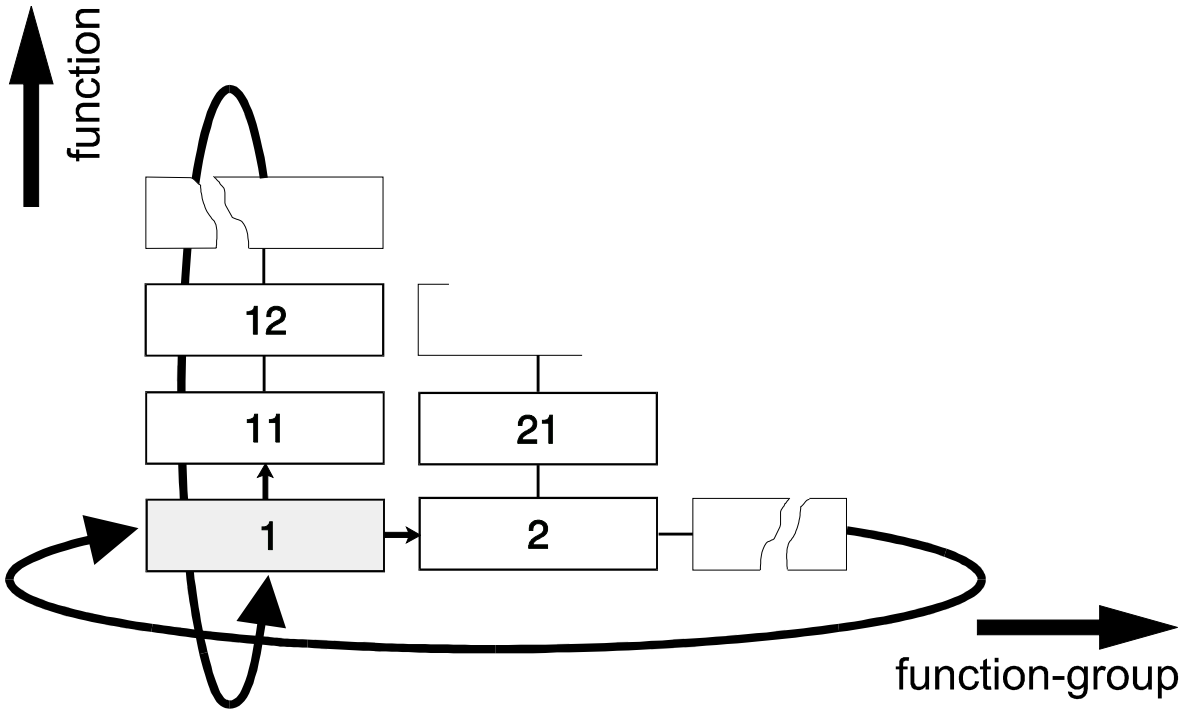

SCROLLING THROUGH SETUP-LEVEL

Selection of function-group and function:

SETUP is divided into several function groups and functions.

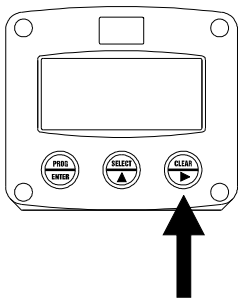

Select function-group with

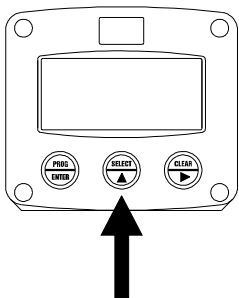

Select function with







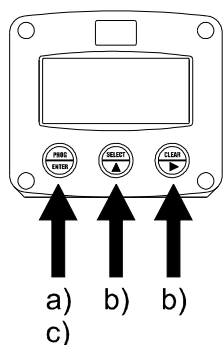

Each function has a unique number, which is displayed below the word "SETUP" at the bottom of the display. The number is a combination of two figures. The first figure indicates the function-group and the second figure the sub-function. Additionally, each function is expressed with a keyword.



After selecting a sub-function, the next main function is selected by scrolling through all "active" sub-functions (e.g. 1▲, 11▲, 12▲, 13▲, 14▲, 1▶, 2▶, 3▲, 31 etc.). The "CLEAR" button can be used to jump a step back if you missed the desired function.



To change or select a value:



- a) press  briefly; **PROGRAM** will start flash
- b) select or enter value with  and / or 
- c) press  to confirm the value / selection.

To change a value, use  to select the digits and  to increase that value.

If the new value is invalid, the increase sign  or decrease-sign  will be displayed while you are programming.

To select a setting,  is used to select in one direction and  can be used to select in the other direction.

When data is altered but ENTER is not pressed, then the alteration can still be cancelled by waiting for 20 seconds or by pressing ENTER for three seconds: the PROG-procedure will be left automatically and the former value reinstated.



Note !

Note: alterations will only be set after ENTER has been pressed!

To return to OPERATOR-level:

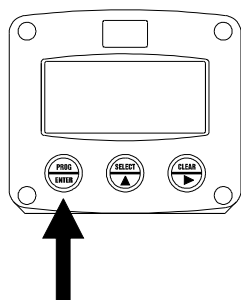

Press  for 3 seconds

In order to return to the operator level, PROG will have to be pressed for three seconds. Also, when no keys are pressed for 2 minutes, SETUP will be left automatically.

SETUP FUNCTIONS AND VARIABLES			
1	TOTAL		
	11	UNIT	L - m3 - kg - lb - GAL - USGAL - bbl - no unit
	12	DECIMALS	0 - 1 - 2 - 3 (Ref: displayed value)
	13	K-FACTOR:	0.000010 - 9,999,999
	14	DECIMALS K-FACTOR	0 - 6
2	FLOWRATE		
	21	UNIT	mL - L - m3 - mg - g - kg - ton - GAL - bbl - lb - cf - REV - no unit - scf - Nm3 - NL - P
	22	TIME UNIT	sec - min - hour - day
	23	DECIMALS	0 - 1 - 2 - 3 (Ref: displayed value)
	24	K-FACTOR	0.000010 - 9,999,999
	25	DECIMALS K-FACTOR	0 - 6
	26	CALCULATION	per 1 - 255 pulses
	27	CUT-OFF	0.1 - 999.9 seconds
3	ALARM		
	31	FLOWZERO	default - no relays - ignore
	32	ALARM LOW	0000.000 - 9,999,999
	33	ALARM HIGH	0000.000 - 9,999,999
	34	DELAY ALARM LOW	0.1 - 999.9 seconds
	35	DELAY ALARM HIGH	0.1 - 999.9 seconds
	36	ALARM OUTPUT	high - low - both
4	DISPLAY		
	41	FUNCTION	total - flowrate
	42	SET ALARM	operator - setup
	43	BACKLIGHT (optional)	off - green - amber
	44	BACKLIGHT ALARM	off - on - flash
	45	BL. BRIGHTNESS	1 - 5
5	POWER MANAGEMENT		
	51	LCD UPDATE	fast - 1 sec - 3 sec - 15 sec - 30 sec - off
	52	BATTERY MODE	operational - shelf
6	FLOWMETER		
	61	SIGNAL	npn - npn_lp - reed - reed_lp - pnp - pnp_lp - namur - coil_hi - coil_lo - active
7	OTHERS		
	71	TYPE / MODEL	Gx013P
	72	SOFTWARE VERSION	03.xx.xx
	73	SERIAL NO.	xxxxxxx
	74	PASS CODE	0000 - 9999
	75	TAGNUMBER	0000000 - 9999999

3.2.3. EXPLANATION OF SETUP-FUNCTIONS

1 - TOTAL	
MEASUREMENT UNIT 11	<p>SETUP - 11 determines the measurement unit for total and accumulated total. The following units can be selected:</p> <p style="text-align: center;">L - m3 - kg - lb. - GAL - USGAL - bbl - _ (no unit).</p> <p>Alteration of the measurement unit will have consequences for operator and SETUP-level values. Please note that the K-factor has to be adapted as well; the calculation is not done automatically.</p>
DECIMALS 12	<p>The decimal point determines for total and accumulated total the number of digits following the decimal point. The following can be selected:</p> <p style="text-align: center;">0000000 - 111111.1 - 22222.22 - 3333.333</p>
K-FACTOR 13	<p>With the K-factor, the flowmeter pulse signals are converted to a quantity. The K-factor is based on the number of pulses generated by the flowmeter per selected measurement unit (SETUP 11), for example per cubic meter. The more accurate the K-factor, the more accurate the functioning of the system will be.</p> <p>Example 1: Calculating the K-factor. <i>Let us assume that the flowmeter generates 2.4813 pulses per liter and the selected unit is "cubic meters / m3". A cubic meter consists of 1000 parts of one liter which implies 2,481.3 pulses per m3. So, the K-factor is 2,481.3. Enter for SETUP - 13: "2481300" and for SETUP - 14 - decimals K-factor "3".</i></p> <p>Example 2: Calculating the K-factor. <i>Let us assume that the flowmeter generates 6.5231 pulses per gallon and the selected measurement unit is gallons. So, the K-Factor is 6.5231. Enter for SETUP - 13: "6523100" and for SETUP - 14 decimals K-factor "6".</i></p>
DECIMALS K-FACTOR 14	<p>This setting determines the number of decimals for the K-factor entered. (SETUP 13). The following can be selected:</p> <p style="text-align: center;">0 - 1 - 2 - 3 - 4 - 5 - 6</p> <p>Please note that this setting influences the accuracy of the K-factor indirectly. (i.e. the position of the decimal point and thus the value given) This setting has NO influence on the displayed number of digits for total (SETUP 12)!</p>

2 - FLOWRATE

The settings for total and flowrate are entirely separate. In this way, different units of measurement can be used for each e.g. cubic meters for total and liters for flowrate.

The display update time for flowrate is one second or more.

Note: these settings also influence the alarm output functions.

MEASUREMENT UNIT 21	<p>SETUP - 21 determines the measurement unit for flowrate. The following units can be selected:</p> <p style="text-align: center;">mL - L - m3 - mg - g - kg - ton - GAL - bbl - lb - cf - REV - no unit - scf - Nm3 - NL - P.</p> <p>Alteration of the measurement unit will have consequences for operator and SETUP-level values. Please note that the K-factor has to be adapted as well; the calculation is not done automatically.</p>
TIME UNIT 22	The flowrate can be calculated per second (SEC), minute (MIN), hour (HR) or day (DAY).
DECIMALS 23	<p>This setting determines for flowrate the number of digits following the decimal point. The following can be selected:</p> <p style="text-align: center;">00000 - 1111.1 - 2222.22 - 3333.333</p>
K-FACTOR 24	<p>With the K-factor, the flowmeter pulse signals are converted to a flowrate. The K-factor is based on the number of pulses generated by the flowmeter per selected measurement unit (SETUP 21), for example per liter. The more accurate the K-factor, the more accurate the functioning of the system will be. For examples read SETUP 13.</p>
DECIMALS K-FACTOR 25	<p>This setting determines the number of decimals for the K-factor (SETUP 24). The following can be selected:</p> <p style="text-align: center;">0 - 1 - 2 - 3 - 4 - 5 - 6</p> <p>Please note that this SETUP - influences the accuracy of the K-factor indirectly. This setting has NO influence on the displayed number of digits for "flowrate" (SETUP 23)!</p>
CALCULATION 26	<p>The flowrate is calculated by measuring the time between a number of pulses, for example 10 pulses. The more pulses the more accurate the flowrate will be. The maximum value is 255 pulses.</p> <p>Note: this setting does influence the update time for the analog output directly (maximum update 10 times a second). If the output response is too slow, decrease the number of pulses.</p> <p>Note: the lower the number of pulses, the higher the power consumption of the unit will be (important for battery powered applications).</p> <p>Note: for low frequency applications (below 10Hz): do not program more than 10 pulses else the update time will be very slow.</p> <p>Note: for high frequency application (above 1kHz) do program a value of 100 or more pulses.</p>
CUT-OFF TIME 27	<p>With this setting, you determine a minimum flow requirement threshold, if during this time less than XXX-pulses (SETUP 26) are generated, the flowrate will be displayed as zero.</p> <p>The cut-off time has to be entered in seconds - maximum time is 999 seconds (about 15 minutes).</p>



Note !



Note !

3 - ALARM

With these settings, it is determined how the flowrate will be monitored and the functionality of the transistor / relay output (terminals 7-8) be determined.

FLOW ZERO 31	When the <u>flowrate is zero</u> , then it is possible to ignore or disable the flowrate monitoring. The following settings can be selected: DEFAULT: in case of a low-flowrate alarm and zero flow, it will switch the alarm output and indicate the alarm on the display. NO RELAY: in case of a low-flowrate alarm and zero flow, it won't switch the alarm output but will indicate the alarm on the display only. IGNORE: in case of a low-flowrate alarm and zero flow, it won't switch the alarm output and nothing will be indicated on the display.
ALARM VALUE LOW FLOWRATE 32	The low alarm is set with this setting. An alarm will be generated as long as the flowrate lower as this value. With value 0.0 this function is disabled.
ALARM VALUE HIGH FLOWRATE 33	The high alarm is set with this setting. An alarm will be generated as long as the flowrate higher as this value. With value 0.0 this function is disabled.
DELAY TIME ALARM LOW FLOWRATE 34	An alarm generated by SETUP 32 "low" can be ignored during X-time period. If the actual flowrate is still incorrect after this delay time, then an alarm will be generated.
DELAY TIME ALARM HIGH FLOWRATE 35	An alarm generated by SETUP 33 "high" can be ignored during X-time period. If the actual flowrate is still incorrect after this delay time, then an alarm will be generated.
ALARM OUTPUT TRANSISTOR / RELAY 36	One transistor or relay output is available to transmit the alarm condition. Assign with this function the type of alarm to be transmitted: low flowrate alarm, high flowrate alarm or both alarms.

4 - DISPLAY

FUNCTION 41	The large 17mm digits can be set to display total or flowrate. When "total" is selected, both total and flowrate are displayed simultaneously. When "flowrate" is selected, only flowrate will be displayed with it's measuring unit while total will be displayed after pressing SELECT.
SET ALARM 42	This function determines if the flowrate alarm values can be set at both Operator level and SETUP-level or SETUP-level only. If SETUP has been selected, the alarm values are still visible for the Operator but can not be changed.
The functions below will only effect the optional LED-backlight.	
BACKLIGHT (OPTION) 43	If a LED backlight has been supplied, the color can be selected. Following selections are available: OFF - GREEN - AMBER
BACKLIGHT ALARM (OPTION) 44	In case the Gx013P generates a flowrate alarm, the backlight can be set to change to red. Following selections are available: OFF: during flowrate alarm the color is according to setting 43 ON: during flowrate alarm the color is red. FLASH: during flowrate alarm the color flashes red and the color as per setting 43.
BRIGHTNESS (OPTION) 45	The density of the backlight can be set in following range: 1 - 5 One is minimum and five is maximum brightness.

5 - POWER MANAGEMENT

When used with the internal battery option, the user can expect reliable measurement over a long period of time. The Gx013P has several smart power management functions to extend the battery life time significantly. Two of these functions can be set:

LCD NEW 51

The calculation of the display-information influences the power consumption significantly. When the application does not require a fast display update, it is **strongly advised** to select a slow refresh rate. Please understand that NO information will be lost; every pulse will be counted and the output signal will be generated in the normal way. The following can be selected:

Fast - 1 sec - 3 sec - 15 sec - 30 sec - off.

Example battery life-time:

life-time with a coil pick-up, 1kHz. pulses and FAST update: about 2 years.

life-time with a coil pick-up, 1kHz. pulses and 1 sec update: about 5 years.

Note: after a button has been pressed by the operator - the display refresh rate will always switch to FAST for 30 seconds. When "OFF" is selected, the display will be switched off after 30 seconds and will be switched on as soon as a button has been pressed.

BATTERY-MODE 52

The unit has two modes: operational or shelf. After "shelf" has been selected, the unit can be stored for several years; it will not process the sensor signal; the display is switched off but all settings and totals are stored. In this mode, power consumption is extremely low. To wake up the unit again, press the SELECT-key twice.



Note !

6 - FLOWMETER

SIGNAL 61

The Gx013P is able to handle several types of input signal. The type of flowmeter pickup / signal is selected with SETUP 61. Read also par. 4.4.2. or 4.4.3 - flowmeter input terminals.

TYPE OF SIGNAL	EXPLANATION	RESISTANCE	FREQ. / mV	REMARK
NPN	NPN input	100kOhm pull-up	6 kHz.	(open collector)
NPN - LP	NPN input with low pass filter	100kOhm pull-up	1.2 kHz.	(open collector) less sensitive
REED	Reed-switch input	1mOhm pull-up	600 Hz.	
REED - LP	Reed-switch input with low pass filter	1mOhm pull-up	120 Hz.	Less sensitive
PNP	PNP input	47kOhm pull-down	6 kHz.	
PNP - LP	PNP input with low pass filter	100kOhm pull-down	1.2 kHz.	Less sensitive
NAMUR	Namur input	820 Ohm pull-down	4 kHz.	External power required
COIL HI	High sensitive coil input	-	20mV p.t.p.	Sensitive for disturbance!
COIL LO	Low sensitive coil input	-	90mV p.t.p.	Normal sensitivity
ACTIVE	Active pulse input detection level 1.2V DC	47kOhm	10KHz.	External power required

7 - OTHERS	
TYPE OF MODEL 71	For support and maintenance it is important to have information about the characteristics of the Gx013P. Your supplier will ask for this information in the case of a serious breakdown or to assess the suitability of your model for upgrade considerations.
VERSION SOFTWARE 72	For support and maintenance it is important to have information about the characteristics of the Gx013P. Your supplier will ask for this information in the case of a serious breakdown or to assess the suitability of your model for upgrade considerations.
SERIAL NUMBER 73	For support and maintenance it is important to have information about the characteristics of the Gx013P. Your supplier will ask for this information in the case of a serious breakdown or to assess the suitability of your model for upgrade considerations.
PASS CODE 74	All SETUP-values can be pass code protected. This protection is disabled with value 0000 (zero). Up to and including 4 digits can be programmed, for example 1234.
TAGNUMBER 75	For identification of the unit and communication purposes, a unique tag number of maximum 7 digits can be entered.

4. INSTALLATION

4.1. GENERAL DIRECTIONS



- **Mounting, electrical installation, start-up and maintenance of this instrument may only be carried out by trained personnel authorized by the operator of the facility. Personnel must read and understand this Operating Manual before carrying out its instructions.**
- **The Gx013P may only be operated by personnel who are authorized and trained by the operator of the facility. All instructions in this manual are to be observed.**
- **Ensure that the measuring system is correctly wired up according to the wiring diagrams. Protection against accidental contact is no longer assured when the housing cover is removed or the panel cabinet has been opened (danger from electrical shock). The housing may only be opened by trained personnel.**
- **Take careful notice of the " Safety rules, instructions and precautionary measures " at the front of this manual.**

4.2. INSTALLATION / SURROUNDING CONDITIONS

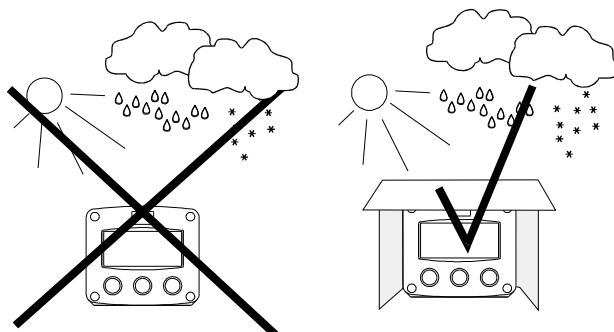

Take the relevant IP classification of the casing into account (see manufactures plate). Even an IP67 (NEMA 4X) casing should NEVER be exposed to strongly varying (weather) conditions.

When panel-mounted, the unit is IP65 (NEMA 4)!

When used in very cold surroundings or varying climatic conditions, take the necessary precautions against moisture by placing a dry sachet of silica gel, for example, inside the instrument case.

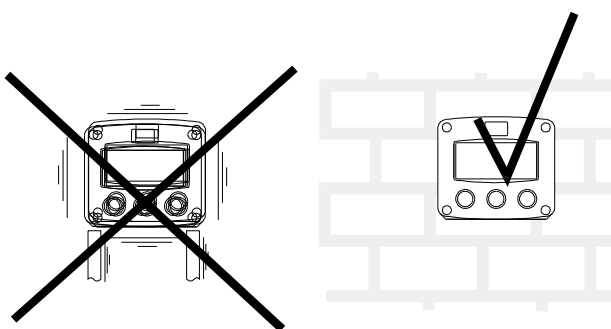

Mount the Gx013P on a solid structure to avoid vibrations.

4.3. DIMENSIONS- ENCLOSURE

Aluminum enclosures:

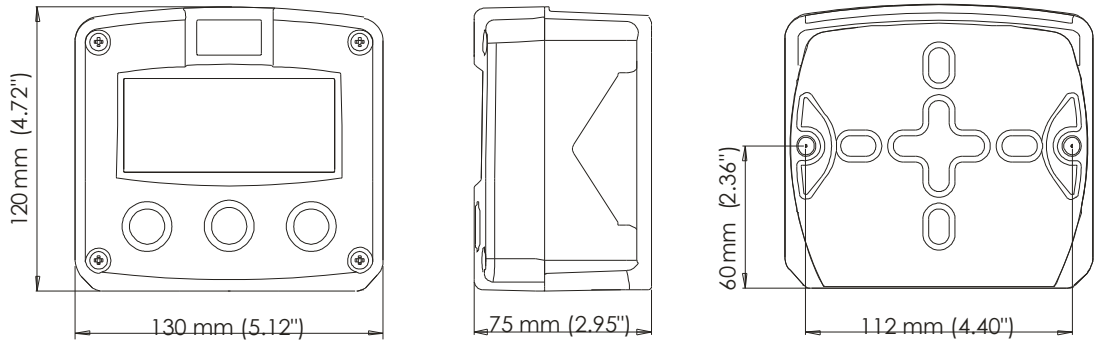

HA

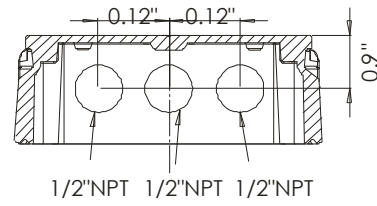
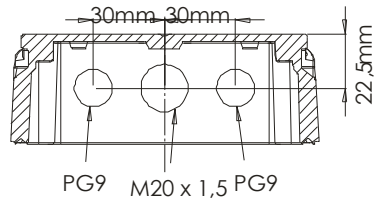

HU

HM

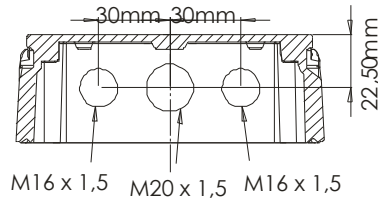

HB

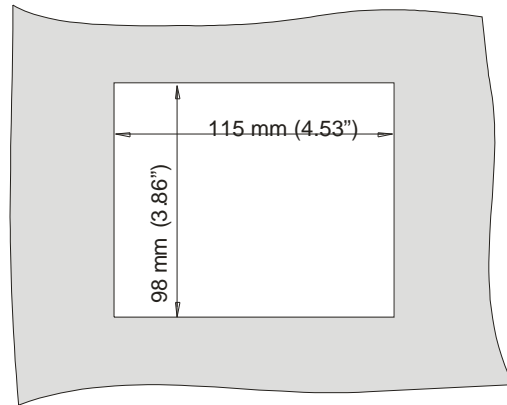
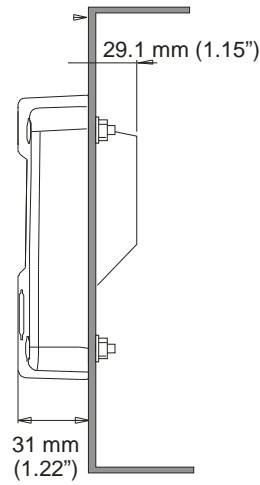

Fig. 6: Dimensions Aluminum enclosures.

GRP enclosures:

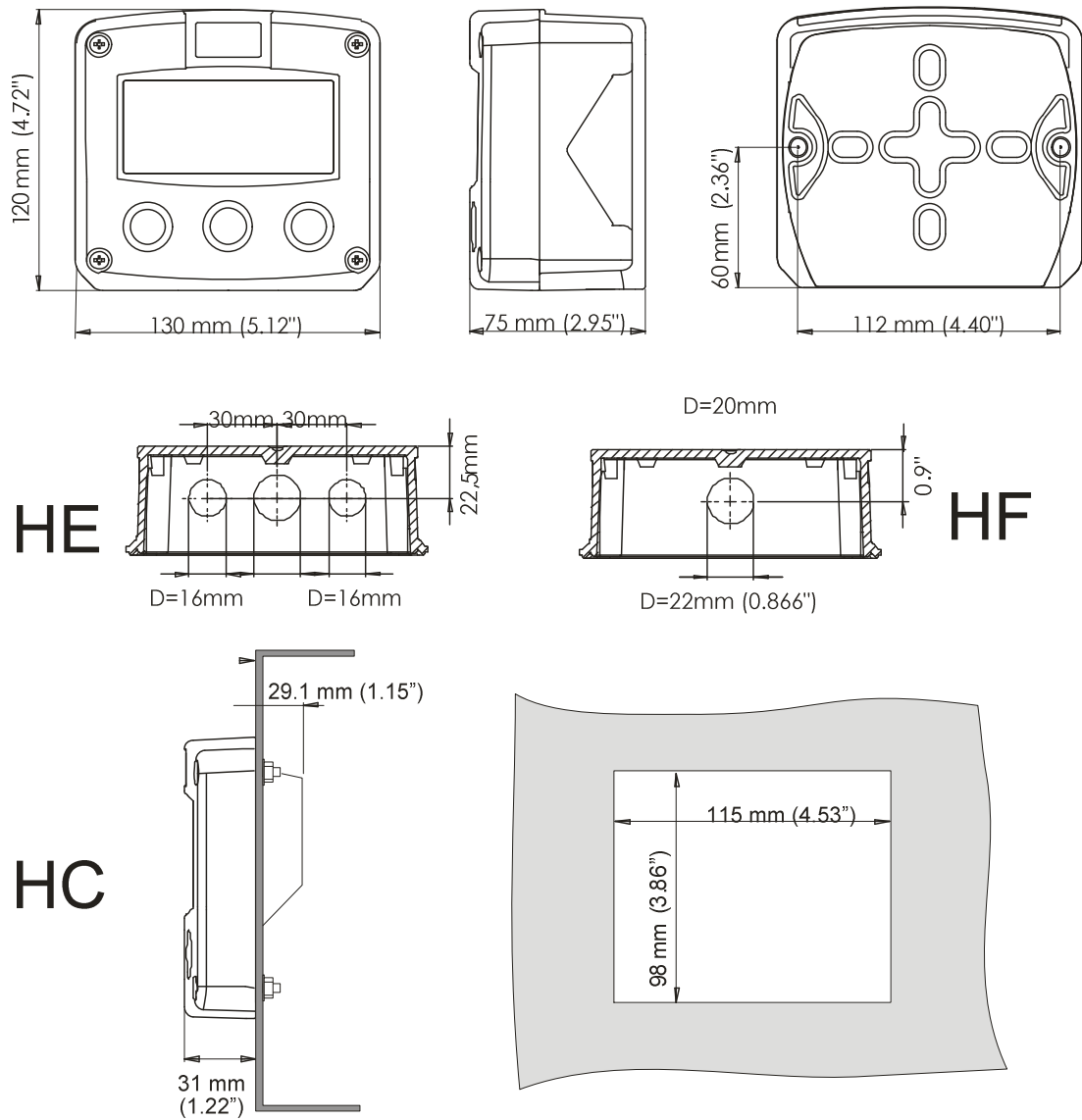

Fig. 7: Dimensions GRP enclosures.

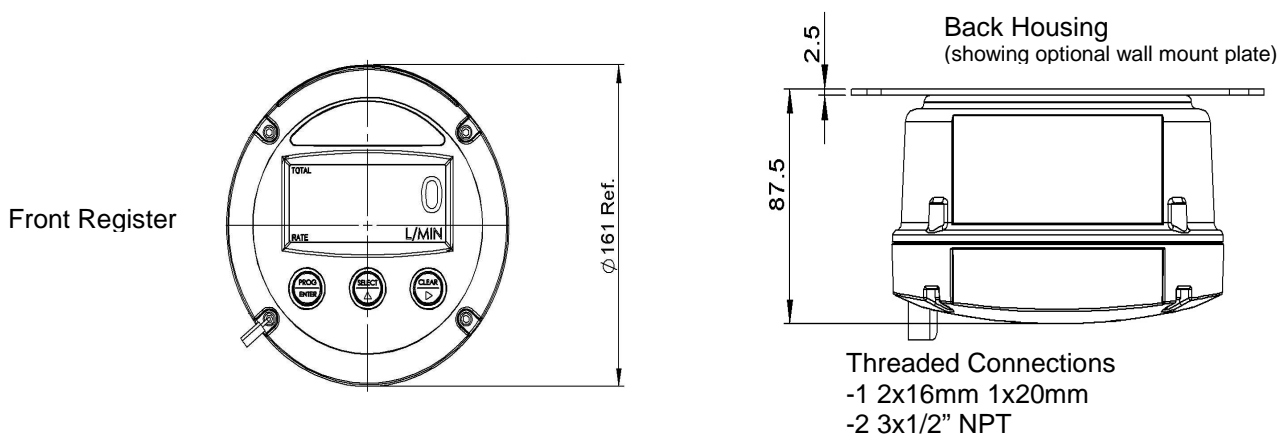

Fig. 6a: Dimensions ER Series meter mount enclosures

Gx013PHxPB Rate Totaliser + Alarm MS531

4.4. INSTALLING THE HARDWARE

4.4.1. INTRODUCTION



- **Electro static discharge does inflict irreparable damage to electronics! Before installing or opening the unit, the installer has to discharge himself by touching a well-grounded object.**



- **This unit must be installed in accordance with the EMC guidelines (Electro Magnetic Compatibility).**



- **Do ground the aluminum casing properly as indicated, if the Gx013P has been supplied with the 115-230V AC power-supply type PM. The green / yellow wire between the back-casing and removable terminal-block may never be removed.**

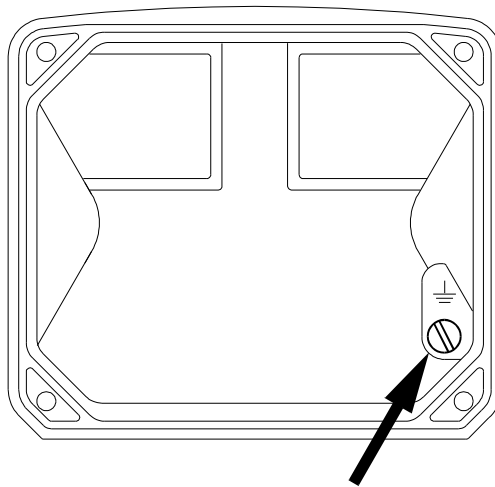

Fig. 8: Grounding aluminum enclosure with option PM 115-230V AC.

FOR INSTALLATION, PAY EMPHATIC ATTENTION TO:

- Separate cable glands with effective IP67 (NEMA4X) seals for all wires.
- Unused cable entries: ensure that you fit IP67 (NEMA4X) plugs to maintain rating.
- A reliable ground connection for both the sensor, and if applicable, for the metal casing. (above)
- An effective screened cable for the input signal, and grounding of it's screen to the "⊥" terminal or at the sensor itself, whichever is appropriate to the application.

4.4.2. TERMINAL CONNECTORS WITH POWER SUPPLY - TYPE : PB / PD / PX

The following terminal connectors are available:

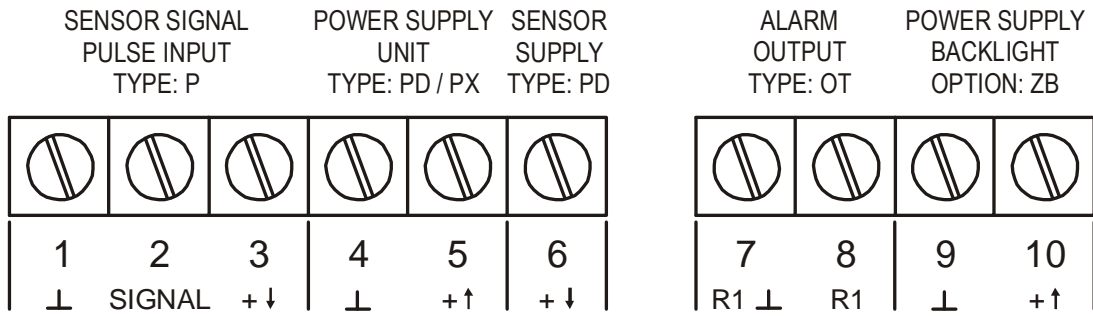

Fig. 9: Overview of terminal connectors Gx013P-(PB / PD / PX) and options.

SENSOR SUPPLY

Type PB / PD / PX - terminal 3: sensor supply 1.2V - 3.2V:

Terminal 3 provides a limited supply voltage of 3.2 V DC (coil signals 1.2V) for the signal output of the flowmeter.



Note !

Note: This voltage MAY NOT be used to power the flowmeters electronics, converters etc, as it will not provide adequate sustained power ! All energy used by the flowmeters pick-up will directly influence the battery life-time (type PB). It is strongly advised to use a "zero power" pickup such as a coil or reed-switch when operating without external power. It is possible to use some low power NPN or PNP output signals, but the battery life time will be significantly reduced (consult your distributor).

Type PD - terminal 6: sensor supply 8.2V:

With this option, a basic but real sensor supply of max. 5mA@8.2V is available to power e.g. a Namur sensor.

REMARKS: TERMINAL CONNECTORS:

Terminals 1-3; Flowmeter input:

Three basic types of flowmeter signals can be connected to the unit: pulse, active pulse or coil. The screen of the signal wire must be connected to the common ground terminal
The input signal type has to be selected with the correct SETUP-function (read par. 3.2.3.)

The Gx013P is suitable for use with flowmeters which have a coil output signal.

Two sensitivity levels can be selected with the SETUP-function:

COIL LO: sensitivity from about 90mVp-p.

COIL HI: sensitivity from about 20mVp-p.

Type ZF (option): offers for setting COIL HI : sensitivity from about 10mVp-p.

Type ZG (option): offers for setting COIL HI : sensitivity from about 5mVp-p.

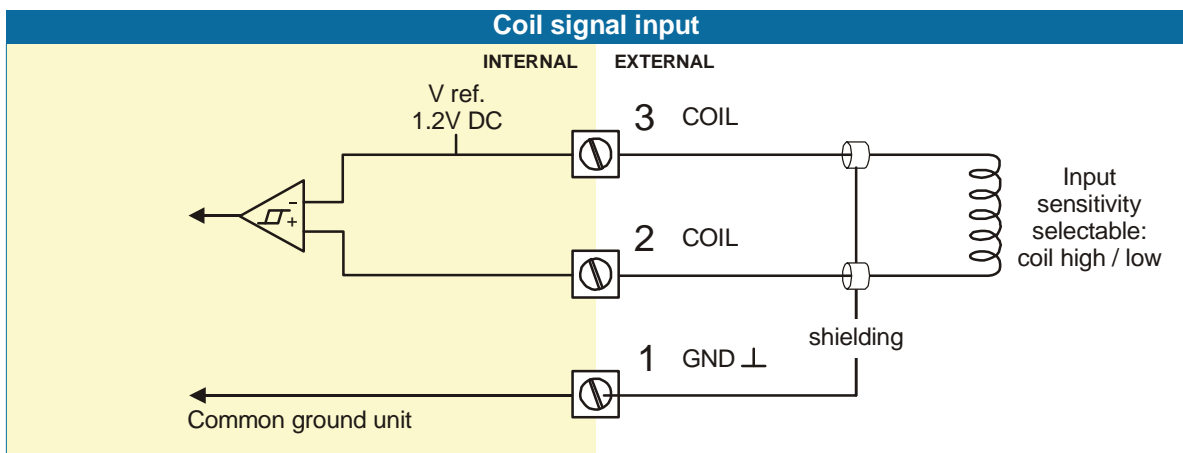

Pulse-signal NPN / NPN-LP:

The Gx013P is suitable for use with flowmeters which have a NPN output signal. For reliable pulse detection, the pulse amplitude has to go below 1.2V. Signal setting NPN-LP employs a low-pass signal noise filter, which limits the maximum input frequency - read par. 3.2.3.

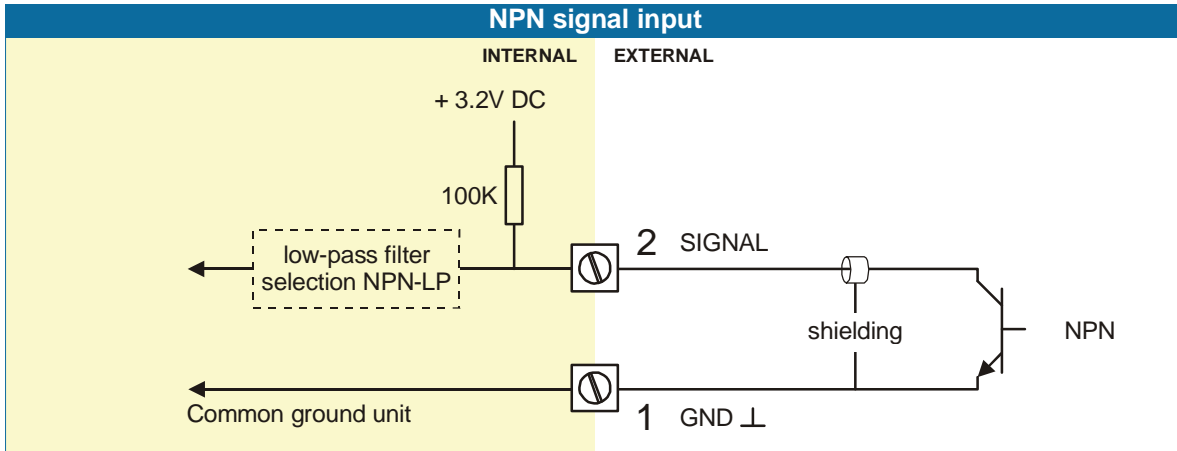

Pulse-signal PNP / PNP-LP:

The Gx013P is suitable for use with flowmeters which have a PNP output signal. Terminal 3 offers 3.2V which has to be switched by the sensor to terminal 2 (SIGNAL). For a reliable pulse detection, the pulse amplitude has to go above 1.2V. Signal setting PNP-LP employs a low-pass signal noise filter, which limits the maximum input frequency - read par. 3.2.3.

A sensor supply voltage of 8.1V DC can be provided with option PD on terminal 6.

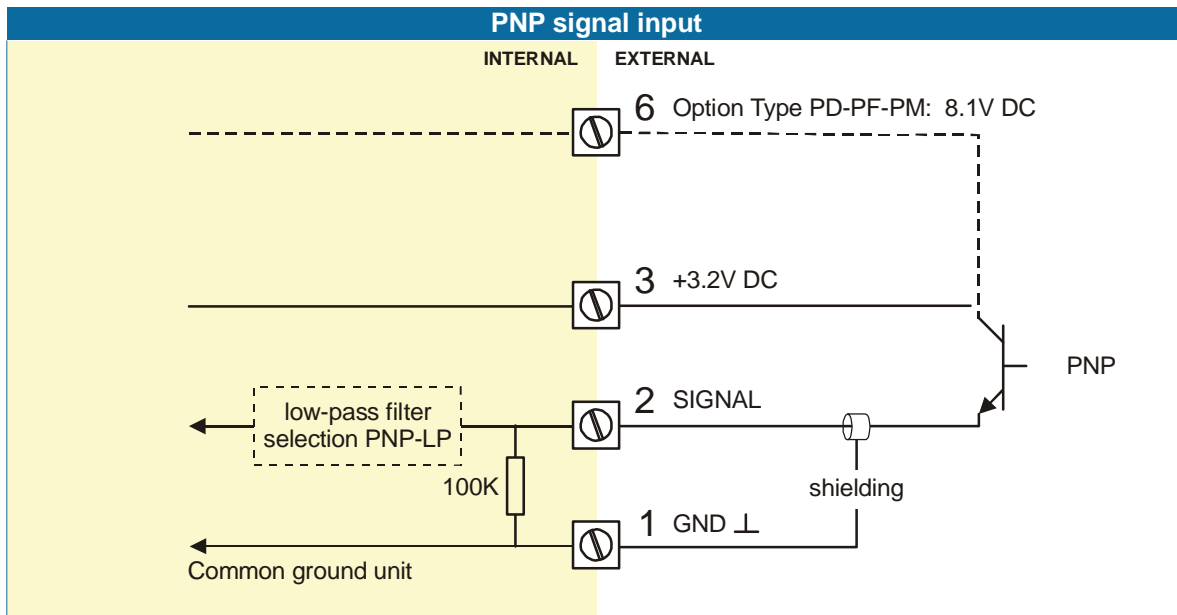

Active signal:

Active signal selection may well be desired in the case of option PD being supplied for sensor supply.

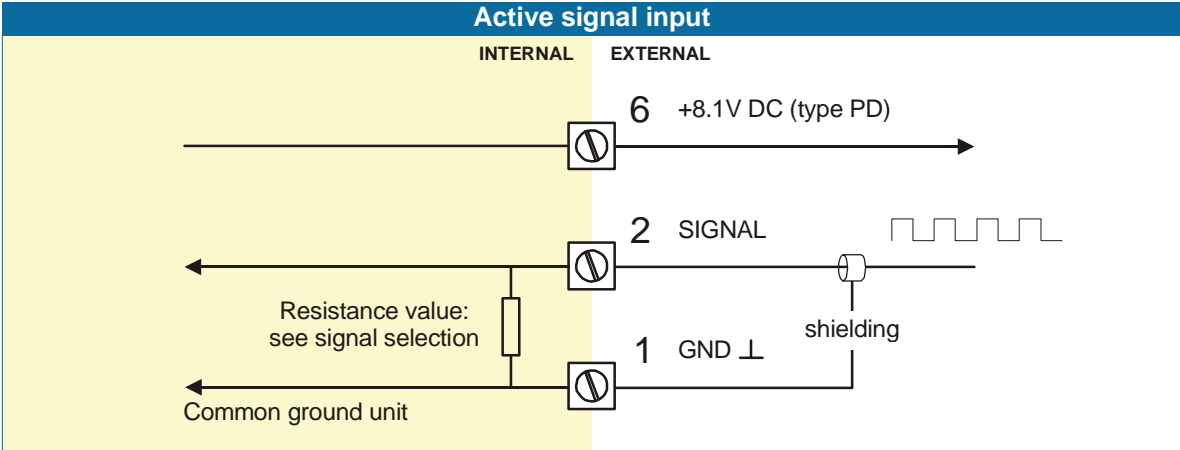

Reed-switch:

The Gx013P is suitable for use with flowmeters which have a reed-switch. To avoid pulse bounce from the reed-switch, it is advised to select REED LP - low-pass filter (read par. 3.2.3.)

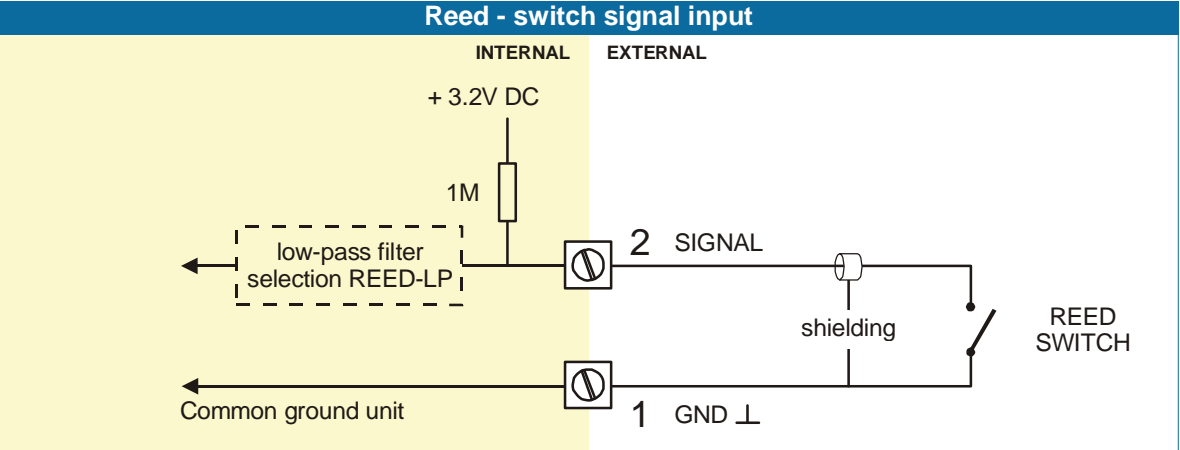

NAMUR-signal:

The Gx013P is suitable for flowmeters with an Namur signal. The standard Gx013P is not able to power the Namur sensor, as an external power supply for the sensor is required. However, a 8.2V sensor supply voltage (terminal 6) can be provided with type PD.

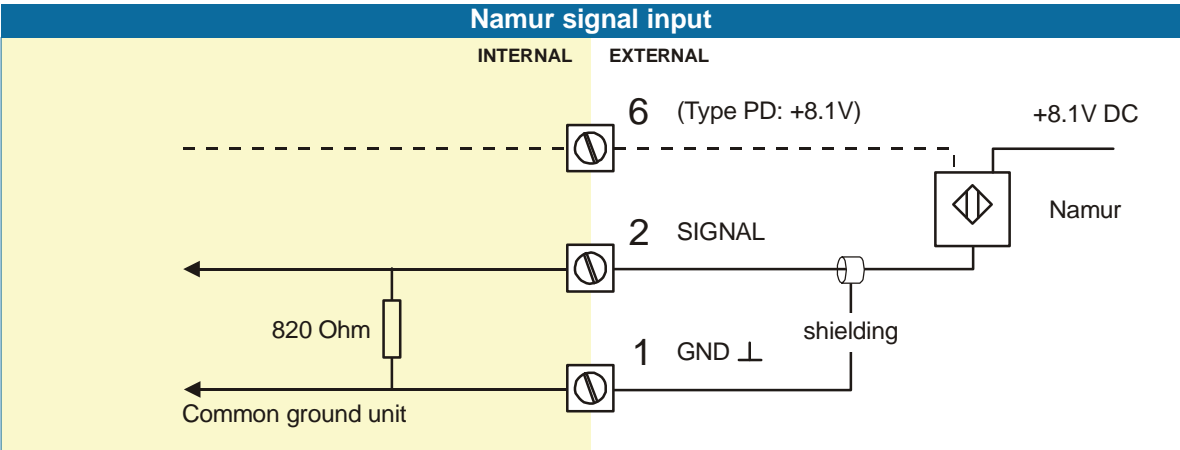

Terminal 4-5: POWER SUPPLY UNIT - TYPE PD / PX:

To power the unit an internal battery can be used (type PB) and / or an external DC power supply of 8-30V DC (type PX) or 16-30V DC (type PD). Connect the "-" to terminal 4 and the "+" to terminal 5. When power is applied to these terminals, the optional internal battery will be disabled / enabled automatically to extend the battery life time.

Terminal 6: Power supply type PD: 8.2V sensor supply.

With this option, a limited power supply for the sensor is available, for example to power a Namur sensor. It offers 8.2V DC (max. 5mA).

Remark: this terminal is only available if option PD has been ordered.

Terminal 7-8; Alarm output – type OT:

With SETUP 36, the function of this output is set to a low and / or high flowrate alarm output. A passive transistor output is available with this option. Max. driving capacity 300mA@50V DC.

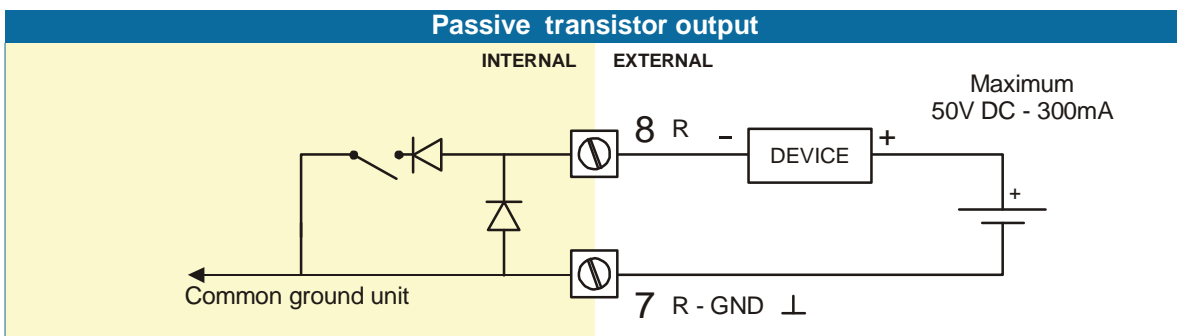

Terminal 9-10: power supply backlight - type ZB (option):

To power the backlight, a voltage in the range 20-30V DC has to be connected. Maximum current 30mA. Connect the "-" to terminal 9 and the "+" to terminal 10.

4.4.3. TERMINAL CONNECTORS WITH POWER SUPPLY - TYPE : PF / PM

The following terminal connectors are available:

POWER SUPPLY TYPE: PF / PM			ALARM OUTPUT TYPE: OA-OR-OT		SENSOR SIGNAL TYPE: P: PULSE INPUT		
GND ⊥	1 N	2 L1	3 R⊥	4 R	5 ⊥	6 SIGNAL	7 +↓

Fig. 10: Overview of terminal connectors Gx013P-(PF / PM) and options.

SENSOR SUPPLY

Type PF-PM: Sensor supply: 1.2, 3.2V, 8.2V, 12V or 24 V:

With this option, a real power supply for the sensor is available. The flowmeter can be powered with 1.2, 3.2, 8.2, 12 or 24 V DC (max. 400mA@24V). The voltage is selected with the three switches inside the enclosure.



- **Warning: be sure that all the leads to the terminals are disconnected from the unit when the internal plastic protection cover has been removed !**
- **HIGH VOLTAGE 400V !! NEVER connect the mains power supply to the unit when the plastic protection cover has been removed !!!**

First, remove the terminal strip(s) after which the internal plastic cover can be removed. The switches are located on the right hand side as indicated:

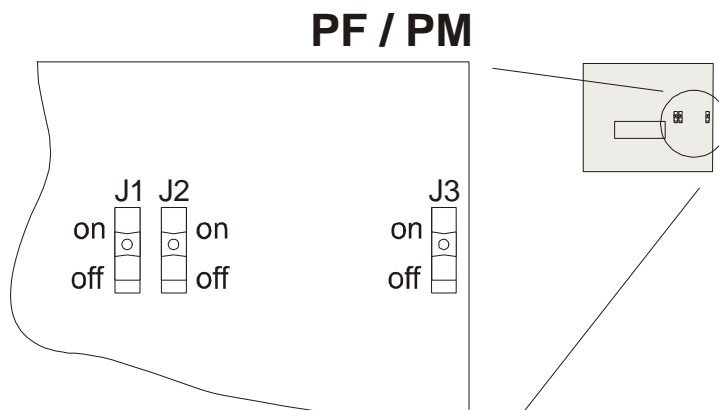

Fig. 11: switch position voltage selection (type PF and PM).

Switch positions / sensor supply voltage:

VOLTAGE SELECTION				
SWITCH	1.2 / 3.2V DC	8.2V DC	12V DC	24V DC
J1	on	off	off	off
J2	on or off	on	on	off
J3	on or off	on	off	on or off

REMARKS: TERMINAL CONNECTORS:

Terminal GND- 01- 02; POWER SUPPLY only available with type PF / PM:

OPTION	SENSOR SUPPLY	Terminal		
		GND	01	02
PF 24V AC \pm 10%	1.2, 3.2, 8.2, 12, 24V max. 400mA@24V DC		AC	AC
PF 24V DC \pm 10%	1.2, 3.2, 8.2, 12, 24V max. 400mA@24V DC	L-	L+	
PM 115-230V AC \pm 10%	1.2, 3.2, 8.2, 12, 24V max. 400mA@24V DC	EARTH	AC	AC
Note PF / PM	The total consumption of the sensor, transistor output type OA and backlight type ZB may not exceed 400mA@24V DC.			

Terminal 3-4; Alarm output:

With SETUP 36, the function of this output is set to a low and / or high flowrate alarm output.

Type OT:

A passive transistor output is available with this option. Max. driving capacity 300mA@50V DC.

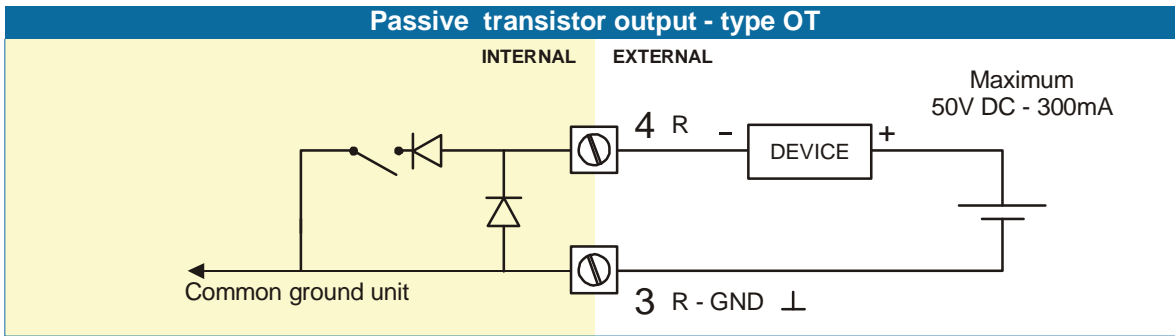

Type OA:

An active 24V DC signal transistor output is available with this option.

Max. driving capacity 400mA@24V DC. (Requires power supply type PF / PM).

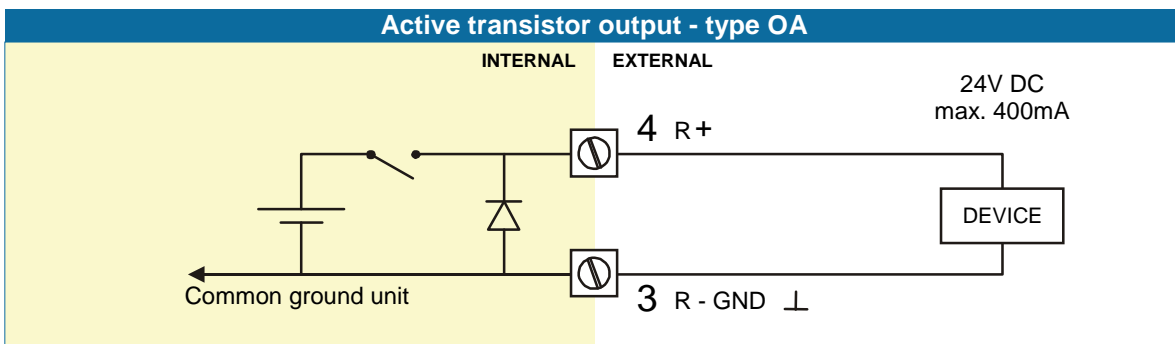

Type OR:

An isolated mechanical relay flowrate alarm output is available with this option.

Max. switch power 240V 0,5A. (Requires power supply type PF / PM).

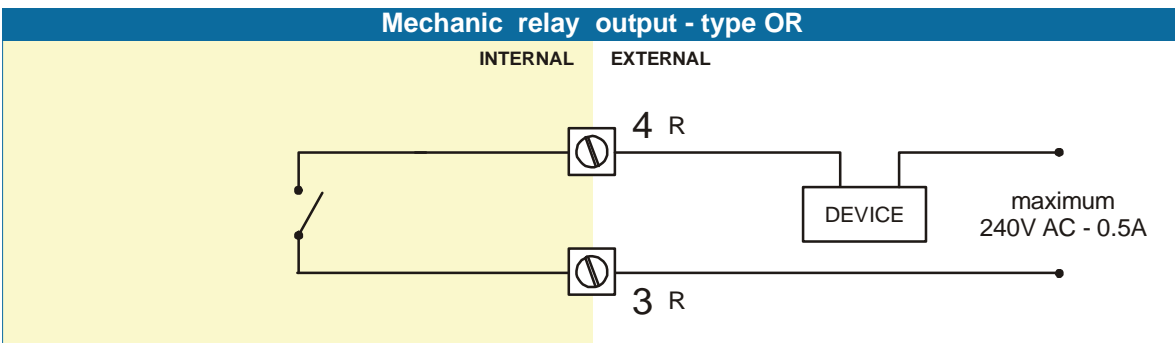

Terminals 5-7; Flowmeter input:

Three basic types of flowmeter signals can be connected to the unit: pulse, active pulse or coil. The screen of the signal wire must be connected to the common ground terminal

The input signal type has to be selected with the correct SETUP-function (read par. 3.2.3.)

Coil-signal:

The Gx013P is suitable for use with flowmeters which have a coil output signal.

Two sensitivity levels can be selected with the SETUP-function:

COIL LO: sensitivity from about 90mVp-p.

COIL HI: sensitivity from about 20mVp-p.

Type ZF (option): offers for setting COIL HI : sensitivity from about 10mVp-p.

Type ZG (option): offers for setting COIL HI : sensitivity from about 5mVp-p.

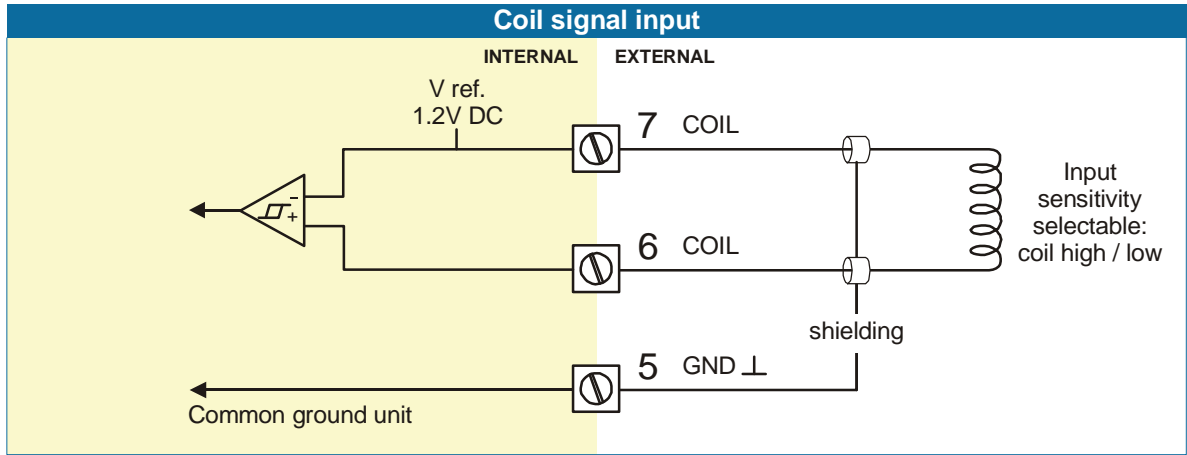

Pulse-signal NPN / NPN-LP:

The Gx013P is suitable for use with flowmeters which have a NPN output signal. For reliable pulse detection, the pulse amplitude has to go below 1.2V. Signal setting NPN-LP employs a low-pass signal noise filter, which limits the maximum input frequency - read par. 3.2.3.

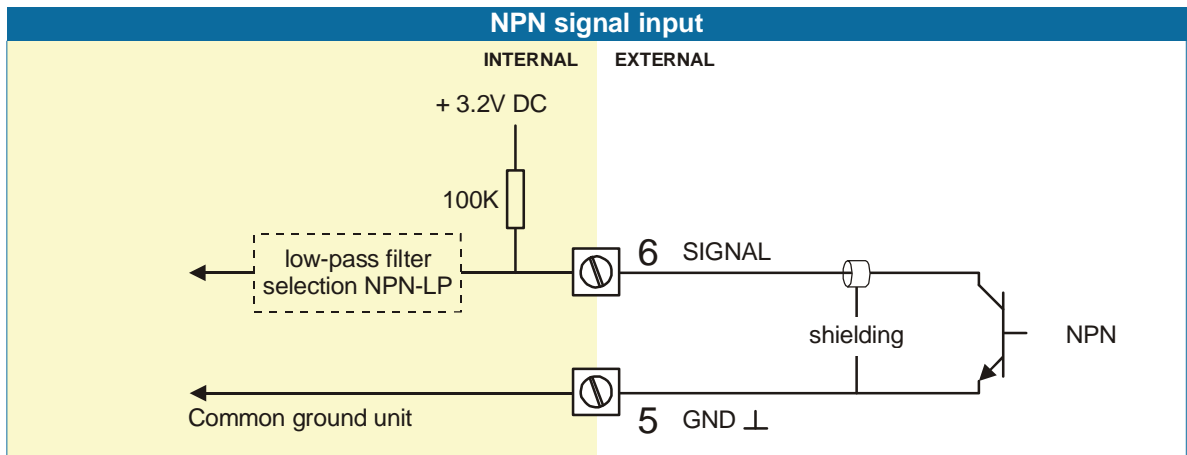

Pulse-signal PNP / PNP-LP:

The Gx013P is suitable for use with flowmeters which have a PNP output signal. For a reliable pulse detection, the pulse amplitude has to go above 1.2V. Signal setting PNP-LP employs a low-pass signal noise filter, which limits the maximum input frequency - read par. 3.2.3. A sensor supply voltage is offered with terminal 7.

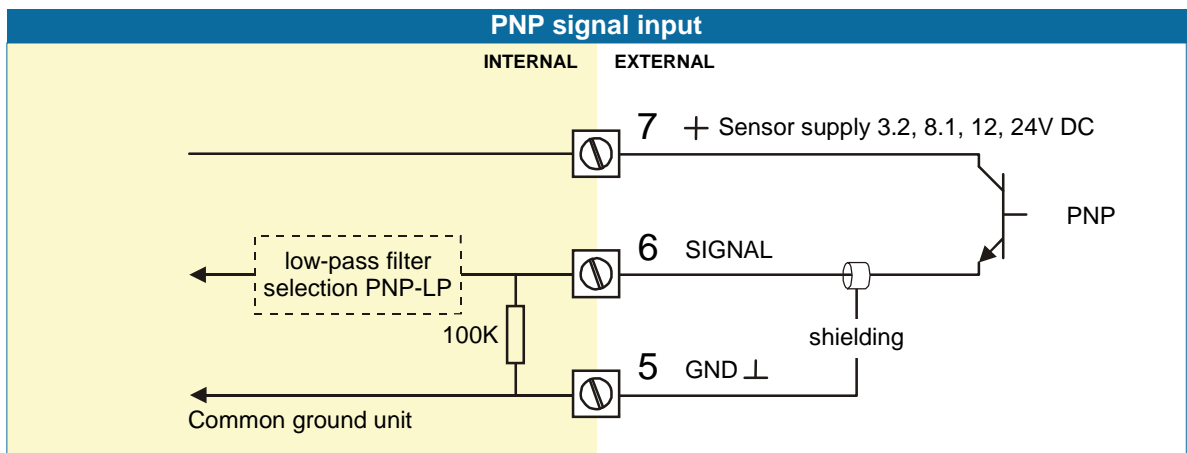

Active signals:

Active signal selection may well be desired if an active signal is offered from the sensor.

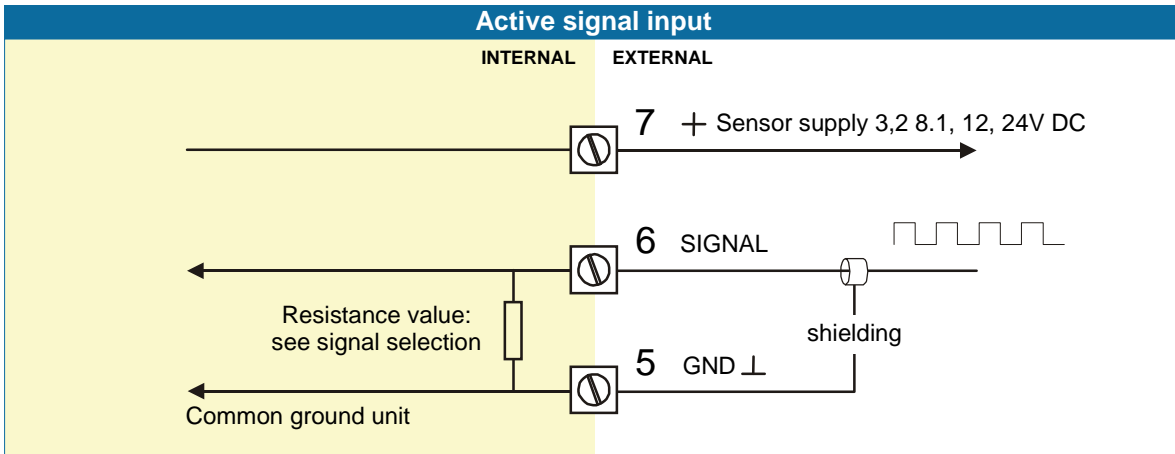

Reed-switch:

The Gx013P is suitable for use with flowmeters which have a reed-switch. To avoid pulse bounce from the reed-switch, it is advised to select REED LP - low-pass filter (read par. 3.2.3.)

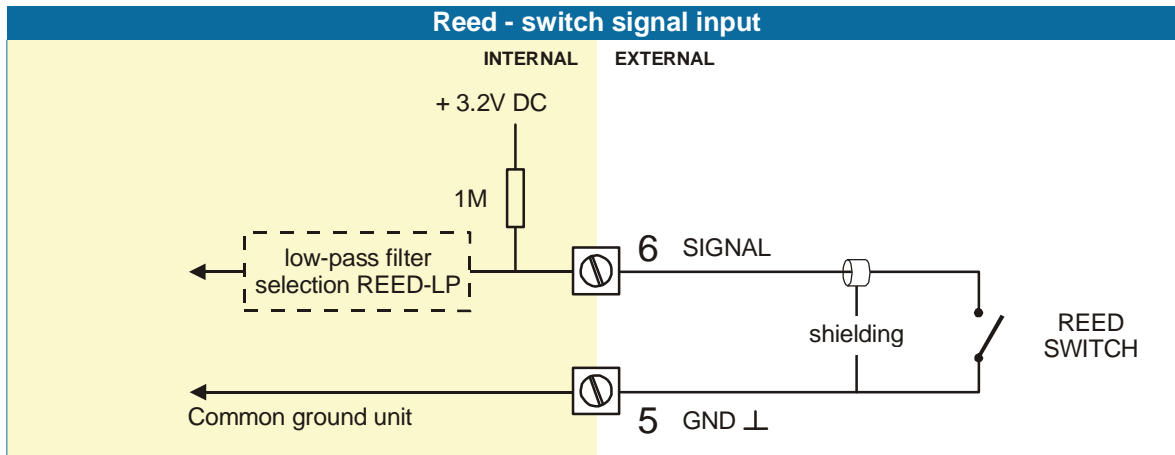

NAMUR-signal:

The Gx013P is suitable for flowmeters with an Namur signal. Terminal 7 can provide a 8.2V sensor supply voltage (please read section "sensor supply").

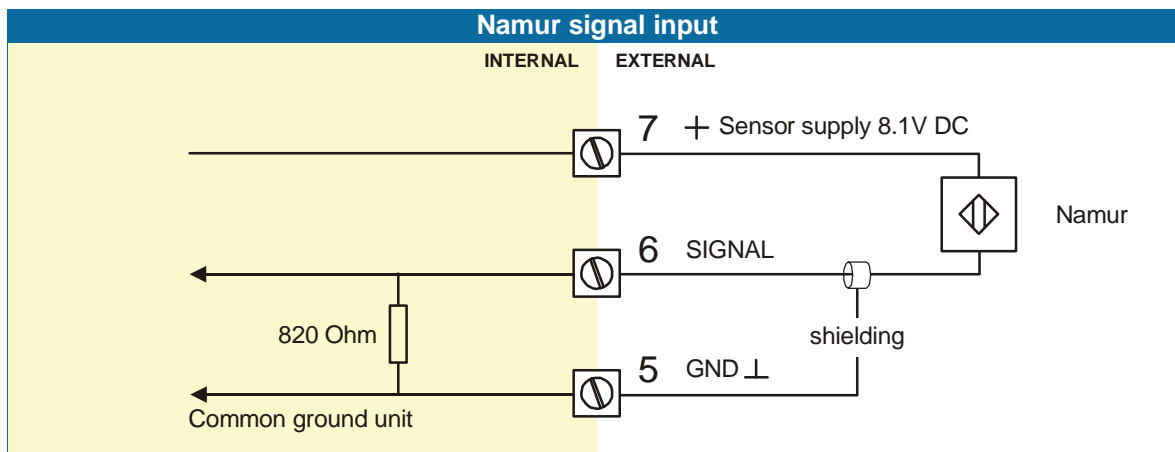

6. MAINTENANCE

6.1. GENERAL DIRECTIONS



Caution !

- ***Mounting, electrical installation, start-up and maintenance of the instrument may only be carried out by trained personnel authorized by the operator of the facility. Personnel must read and understand this Operating Manual before carrying out its instructions.***
- ***The Gx013P may only be operated by personnel who are authorized and trained by the operator of the facility. All instructions in this manual are to be observed.***
- ***Ensure that the measuring system is correctly wired up according to the wiring diagrams. Protection against accidental contact is no longer assured when the housing cover is removed or the panel cabinet has been opened (danger from electrical shock). The housing may only be opened by trained personnel.***
- ***Take careful notice of the " Safety rules, instructions and precautionary measures " in the front of this manual.***

The Gx013P does not require special maintenance unless it is used in low-temperature applications or surroundings with high humidity (above 90% annual mean). It is the users responsibility to take all precautions to dehumidify the internal atmosphere of the Gx013P in such a way that no condensation will occur, for example by placing dry silica-gel sachet in the casing just before closing it. Furthermore, it is required to replace or dry the silica gel periodically as advised by the silica gel supplier.

Battery life-time:

It is influenced by several issues :

- Type of sensor: read chapter 3.2.3. NPN and PNP inputs consume more energy than coil inputs.
- Input frequency: the higher the frequency, the shorter the battery life-time.
- Flowrate calculation: the lower number of pulses (SETUP 26) the shorter the battery life-time.
- Display update: fast display update uses significantly more power.
- Alarm output.
- Low temperatures; the available power will be less due to battery chemistry.



Note !

Note: *It is strongly advised to use only necessary functions.*

Check periodically:

- The condition of the casing, cable glands and front panel.
- The input/output wiring for reliability and aging symptoms.
- The process accuracy. As a result of wear and tear, re-calibration of the flowmeter might be necessary. Do not forget to re-enter any subsequent K-factor alterations.
- The indication for low-battery.
- Clean the casing with soapy-water. Do not use any aggressive solvents as these might damage the coating.

6.2. REPAIR

This product cannot be repaired by the user and must be replaced with an equivalent certified product. Repairs should only be carried out by the manufacturer or his authorized agent.

APPENDIX A: TECHNICAL SPECIFICATION**GENERAL**

Display	
Type	High intensity reflective numeric and alphanumeric LCD, UV-resistant.
Digits	Seven 17mm (0.67") and eleven 8mm (0.31"). Various symbols and measuring units.
Refresh rate	User definable: 8 times/sec - 30 secs.
Type ZB (option)	Tri-color configurable LED-backlight - green, amber with red flashing during alarm. Intensity adjustable from the keyboard.

Enclosures	
General	Die-cast aluminum or GRP (Glassfibre Reinforced Polyamide) enclosure with Polycarbonate window, silicone and EPDM gaskets. UV stabilized and flame retardant material.
Control Keys	Three industrial micro-switch keys. UV-resistant silicone keypad.
Painting	Aluminum enclosure only: UV-resistant 2-component industrial painting.
Panel-mount enclosures	Dimensions: 130 x 120 x 60mm (5.10" x 4.72" x 2.38") – LxHxD.
Classification	IP65 / NEMA4
Panel cut-out	115 x 98mm (4.53" x 3.86") LxH.
Type HC	GRP panel-mount enclosure
Type HB	Aluminum panel-mount enclosure
Field/wall-mount enclosures	Dimensions: 130 x 120 x 75mm (5.10" x 4.72" x 2.95") – LxHxD.
Classification	IP67 / NEMA4X
Aluminum enclosures	
Type HA	Drilling: 2x PG9 – 1x M20.
Type HM	Drilling: 2x M16 – 1x M20.
Type HN	Drilling: 1x M20.
Type HO	Drilling: 2x M20.
Type HP	Drilling: 6x M12.
Type HT	Drilling: 1x ½"NPT.
Type HU	Drilling: 3x ½"NPT.
Type HZ	No drilling.
GRP enclosures	
Type HD	No drilling.
Type HE	Drilling: 2x 16mm (0.63") – 1x 20mm (0.78").
Type HF	Drilling: 1x 22mm (0.87").
Type HG	Drilling: 2x 20mm (0.78").
Type HH	Drilling: 6x 12mm (0.47").
Type ZS	Silicone free ABS enclosure with EPDM and PE gaskets. UV-resistant polyester keypad. Note: this option comes with type HD only.

Operating temperature	
Operational	-40°C to +80°C (-40°F to +178°F).
Intrinsically Safe	-40°C to +70°C (-40°F to +158°F).

Power requirements	
Type PB	Lithium battery - life-time depends upon settings - up to 5 years.
Type PC	Intrinsically Safe lithium battery - life-time depends upon settings - up to 5 years.
Type PD	16-30 V DC. Power consumption max. 1 Watt.
Type PF	24V AC/DC $\pm 10\%$. Power consumption max. 15 Watt.
Type PL	Input loop powered from 4-20mA signal input. Voltage drop max. 2.6V DC
Type PM	115-230V AC $\pm 10\%$. Power consumption max. 15 Watt.
Type PX	8-30 V DC (also available with PB / PC). Power consumption max. 0.3 Watt.
Type ZB	20-30V DC. Power consumption max. 1 Watt. Note: with type PF / PM: internally powered.
Note PF / PM	The total consumption of the sensor, active output type OA and backlight type ZB may not exceed 400mA@24V DC.
Note I.S. application	for intrinsically safe applications, consult the safety values in the certificate.

Sensor excitation	
Type PB / PC / PX	Sensor supply voltage: 3.2V DC for pulse signals and 1.2V DC for coil pick-up. Please note: this is not a real sensor supply. Only suitable for sensors with a very low power consumption like coils (sine wave) and reed-switches. Analog sensors type A / U: sensor supply not available.
Type PD	With pulse input type P: sensor supply 1.2, 3.2, 8.2V DC - max. 5mA@8.2V DC. With analog input type A / U: as connected power supply voltage (internally linked)
Type PF / PM	Analog sensors type A / U: sensor supply 8.2, 12 and 24V DC - max. 400mA@24V DC With pulse input type P: sensor supply 1.2, 3.2, 8.2, 12 and 24V DC - max. 400mA@24V DC

Terminal connections	
Type:	Removable plug-in terminal strip. Wire max. 1.5mm ² and 2.5mm ²

Data protection	
Type	EEPROM backup of all settings. Data retention at least 10 years.
Pass code	Configuration settings can be pass code protected.

Hazardous area (option)	
Intrinsically safe Type XI	ATEX approval ref.: <EX> II 1 GD EEx ia IIC T4 T100°C IECEx, CSA and FM approval is expected to be available May 2007.
Explosion proof Type XF	ATEX approval ref.: <EX> II 2 GD EEx d IIB T5. Weight appr. 15kg. Dimensions of enclosure: 350 x 250 x 200mm (13.7" x 9.9" x 7.9") LxHxD.

Environment	
Electromagnetic compatibility	Compliant ref: EN 61326 (1997), EN 61010-1 (1993)
Low voltage directive	Compliant ref: EN60950.

INPUT

Flowmeter	
Type P	Coil/sine wave (minimum 20mVpp or 80mVpp - sensitivity selectable), NPN/PNP, open collector, reed-switch, Namur, active pulse signals.
Frequency	Minimum 0 Hz - maximum 7 kHz for flowrate. Maximum frequency depends on signal type and internal low-pass filter. E.g. Reed switch with low-pass filter: max. frequency 120 Hz.
K-Factor	0.000010 - 9,999,999 with variable decimal position.
Low-pass filter	Available for all pulse signals.
Note	For coil signal input: higher sensitivity is available - type ZF (10mVpp) / type ZG (5mVpp).
Type A	(0)4-20mA - with signal calibration feature.
Type U	0-10 V - with signal calibration feature.
Accuracy	Resolution: 16 bit.. Error < 0.01mA / ±0.05% FS. Low level cut-off programmable.
Span	0.001 - 99,999 with variable decimal position.
Update time	Four times a second.
Voltage drop	2.6 Volt.
Load impedance	3kOhm
Relationship	Linear and square root calculation.
Note	For signal type A and U: external power to sensor is required; e.g. type PD / PF / PM.

OUTPUT

Alarm output	
Function	high, low or high and low flowrate alarm.
Type OT	One passive transistor output - not isolated. Load max. 50V DC - 300mA.
Type OA	One active 24V DC transistor output; max. 400mA per output (requires type PF or PM).
Type OR	One mechanic relay output; max. switch power 230V AC - 0,5A (requires type PF or PM).

OPERATIONAL

Operator functions	
Displayed functions	<ul style="list-style-type: none"> total and/or flowrate. total and accumulated total. total can be reset to zero by pressing the CLEAR-key twice. alarm value's low - high flowrate alarm value's can be entered (this function can be disabled)

Total	
Digits	7 digits.
Units	L, m3, GAL, USGAL, KG, lb, bbl, no unit.
Decimals	0 - 1 - 2 or 3.
Note	total can be reset to zero.

Accumulated total	
Digits	11 digits.
Units / decimals	according to selection for total.

Flowrate	
Digits	7 digits.
Units	mL, L, m3, Gallons, KG, Ton, lb, bl, cf, RND, ft3, scf, Nm3, NI, igal - no units.
Decimals	0 - 1 - 2 or 3.
Time units	/sec - /min - /hr - /day.

Alarm values	
Digits	7 digits.
Units	According to selection for flowrate.
Decimals	According to selection for flowrate.
Time units	According to selection for flowrate.
Type of alarm	low and high flowrate alarm. Includes delay time alarm and configurable alarm output.

APPENDIX B: PROBLEM SOLVING

In this appendix, several problems are included that can occur when the Gx013P is going to be installed or while it is in operation.

Flowmeter does not generate pulses:

Check:

- Signal selection SETUP - 61,
- Pulse amplitude (par. 4.4.2. / 4.4.3.),
- Flowmeter, wiring and connection of terminal connectors (par. 4.4.2. / 4.4.3.),
- Power supply of flowmeter (par. 4.4.2. / 4.4.3.).

Flowmeter generates "too many pulses":

Check:

- Settings for total and Flowrate: SETUP 11-14 and 21-27,
- Type of signal selected with actual signal generated - SETUP - 61,
- Sensitivity of coil input - SETUP - 61 and par. 4.4.2 / 4.4.3.
- Proper grounding of the Gx013P - par. 4.4.1.
- Use screened wire for flowmeter signals and connect screen to the "L" terminal.

Flowrate displays "0 / zero" while there is flow (total is counting):

Check:

- SETUP 22 / 25: are the K-factor and time unit correct?
- SETUP 26 / 27: The unit has to count the number of pulses according to SETUP 26 within the time according to SETUP 27. Make sure that 27 is set to 10.0 seconds for example : the result is that the unit has at least 10 seconds time to measure the number of pulses according to SETUP 26.

The pass code is unknown:

If the pass code is not 1234, there is only one possibility left: call your supplier.

ALARM

When the alarm flag starts to blink an internal alarm condition has occurred. Press the "select button" several times to display the 5-digit error code. The codes are:

0001: irrecoverable display-data error: data on the display might be corrupted.

0002: irrecoverable data-storage error: the programming cycle might have gone wrong: check programmed values.

0003: error 1 and error 2 occurred simultaneously

The alarm condition will almost certainly be handled internally and if all mentioned values still appear correct, no intervention by the operator is needed. If the alarm occurs more often or stays active for a longer time, please contact your supplier.

INDEX OF THIS MANUAL

accumulated total	7	time unit	14
active pulse signal	24, 29	functional description	5
actual settings	40	high alarm output	25
alarm		installation	18
alarm output function	15	IP classification	18
alarm values	15	keys	6
delay time alarm	15	low-battery	8
display flow zero	15	main-function	10
set alarm operator level	15	maintenance	34
alarm output	25, 27	model	17
alarm values	8	namur signal	24, 29
backlight	25	operational	6
alarm color	15	operator level	7
color	15	pass code	17, 38
density	15	power supply	25, 26
battery life time	15, 16, 34	problem solving	38
clear total	7	pulse-signal NPN	23, 28
coil-signal	22, 27	pulse-signal PNP	23, 28
configuration	9	rate / total	7
contents	4	reed-switch:	24, 29
dimensions	19	safety instructions	2
display		sensor supply voltage	22, 25, 26
function	15	serial number	17
display update time	16	setup-level	9
flowmeter		subfunction	10
signal	16	tagnumber	17
flowmeter input	22, 27	technical specification	35
flowrate		terminal connectors	22, 25
alarm	8	total	
calculation	14	decimals	13
cut-off time	14	decimals k-factor	13
decimals	14	k-factor	13, 14
decimals k-factor	14	measuring unit	13
enter alarm value	8	version software	17
measuring unit	14	voltage selection sensor supply	26

LIST OF FIGURES IN THIS MANUAL

Fig. 1: Typical application for the Gx013P.....	5
Fig. 2: Control Panel.....	6
Fig. 3: Example of display information during process.....	7
Fig. 4: Example of display information during programming minimum flowrate.....	8
Fig. 5: Example of low-battery alarm.....	8
Fig. 6: Dimensions Aluminum enclosures.....	20
Fig. 7: Dimensions GRP enclosures.....	21
Fig. 8: Grounding aluminum enclosure with option PM 115-230V AC.....	22
Fig. 9: Overview of terminal connectors Gx013P-(PB / PD / PX) and options.....	23
Fig. 10: Overview of terminal connectors Gx013P-(PF / PM) and options.....	26
Fig. 11: switch position voltage selection (type PF and PM).....	27

LIST OF CONFIGURATION SETTINGS			
SETTING	DEFAULT	DATE :	DATE :
1 - TOTAL	Enter your settings here		
11 unit	L		
12 decimals	0000000		
13 K-factor	0000001		
14 decimals K-factor	0		
2 - FLOWRATE	Enter your settings here		
21 unit	L		
22 time unit	/min		
23 decimals	0000000		
24 K-factor	0000001		
25 decimals K-factor	0		
26 calculation / pulses	010		
27 cut-off time	30.0 sec.		
3 - ALARM	Enter your settings here		
31 flow zero	default		
32 alarm value low	0		
33 alarm value high	0		
34 delay time alarm low	0.0 sec		
35 delay time alarm high	0.0 sec		
36 alarm output	hi - lo		
4 - DISPLAY	Enter your settings here		
41 function	total		
42 set rate min/max	operator level		
43 backlight	off		
44 backlight alarm	off		
45 brightness	5		
5 - POWER MANAGEMENT	Enter your settings here		
51 LCD-new	1 sec.		
52 mode	operational		
6 - FLOWMETER	Enter your settings here		
61 signal	coil-lo		
7 - OTHERS	Enter your settings here		
71 model	Gx013P	Gx013P	Gx013P
72 software version	03.____.____	03.____.____	03.____.____
73 serial number	-----	-----	-----
74 pass code	0000		
75 tagnumber	0000000		