

MS392
0210
0003

***ERB (meter mount)***

***RG030***

***RA030***

***BATCH-CONTROLLER***

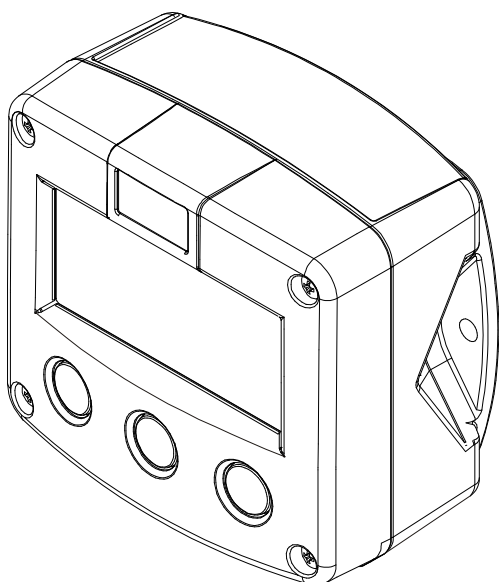

***Signal input flowmeter type P: pulse, Namur and coil.***

***Control output: one control output for one stage batching.***

***Options: Intrinsically Safe.***

## SAFETY INSTRUCTIONS



- **Any responsibility is lapsed if the instructions and procedures as described in this manual are not followed.**



- **LIFE SUPPORT APPLICATIONS: The ERB/Rx030 is not designed for use in life support appliances, devices, or systems where malfunction of the product can reasonably be expected to result in a personal injury. Customers using or selling these products for use in such applications do so at their own risk and agree to fully indemnify the manufacturer and supplier for any damages resulting from such improper use or sale.**



- **Electro static discharge does inflict irreparable damage to electronics! Before installing or opening the unit, the installer has to discharge himself by touching a well-grounded object.**



- **This unit must be installed in accordance with the EMC guidelines (Electro Magnetic Compatibility).**



- **Do connect a proper grounding to the aluminum casing as indicated if the ERB/Rx030 has been supplied with the 115-230V AC power-supply type PM. The green / yellow wire between the back-casing and removable terminal-block may never be removed.**



- **Intrinsically Safe applications: follow the instructions as mentioned in Chapter 5.**

## SAFETY RULES AND PRECAUTIONARY MEASURES

- The manufacturer accepts no responsibility whatsoever if the following safety rules and precautions instructions and the procedures as described in this manual are not followed.
- Modifications of the ERB/Rx030 implemented without preceding written consent from the manufacturer, will result in the immediate termination of product liability and warranty period.
- Installation, use, maintenance and servicing of this equipment must be carried out by authorized technicians.
- Check the mains voltage and information on the manufacturer's plate before installing the unit.
- Check all connections, settings and technical specifications of the various peripheral devices with the ERB/Rx030 supplied.
- Open the casing only if all leads are free of potential.
- Never touch the electronic components (ESD sensitivity).
- Never expose the system to heavier conditions than allowed according to the casing classification (see manufacture's plate and chapter 4.2.).
- If the operator detects errors or dangers, or disagrees with the safety precautions taken, then inform the owner or principal responsible.
- The local labor and safety laws and regulations must be adhered to.

## ABOUT THE OPERATION MANUAL

This operation manual is divided into two main sections:

- The daily use of the unit is described in chapter 2 "Operation". These instructions are meant for users.
- The following chapters and appendices are exclusively meant for electricians/technicians. These provide a detailed description of all software settings and hardware installation guidance.

This operation manual describes the standard unit as well as most of the options available. For additional information, please contact your supplier.

**A hazardous situation may occur if the ERB/Rx030 is not used for the purpose it was designed for or is used incorrectly. Please carefully note the information in this operating manual indicated by the pictograms:**



A "**warning**" indicates actions or procedures which, if not performed correctly, may lead to personal injury, a safety hazard or damage of the ERB/Rx030 or connected instruments.



Caution !

A "**caution**" indicates actions or procedures which, if not performed correctly, may lead to personal injury or incorrect functioning of the ERB/Rx030 or connected instruments.



Note !

A "**note**" indicates actions or procedures which, if not performed correctly, may indirectly affect operation or may lead to an instrument response which is not planned.

Hardware version	:	FB03.03.xx
Software version	:	03.02.xx
Manual	:	MS392
© Copyright 2008	:	

**Information in this manual is subject to change without prior notice. The manufacturer is not responsible for mistakes in this material or for incidental damage caused as a direct or indirect result of the delivery, performance or use of this material.**

**© All rights reserved. No parts of this publication may be reproduced or used in any form or by any means without written permission of your supplier.**

# CONTENTS MANUAL

Safety instructions .....	2
Safety rules and precautionary measures .....	2
About the operation manual .....	3
Contents manual.....	4
1. Introduction.....	5
1.1. System description of the ERB/Rx030.....	5
2. Operational.....	7
2.1. General .....	7
2.2. Control panel.....	7
2.3. Operator information and functions.....	8
3. Configuration .....	10
3.1. Introduction .....	10
3.2. Programming SETUP-level.....	10
3.2.1. General .....	10
3.2.2. Overview functions SETUP level .....	14
3.2.3. Explanation OF SETUP-functions.....	15
1 - Preset .....	15
2 - Overrun.....	16
3 - Display .....	16
4 - Power management.....	16
5 - Flowmeter .....	17
6 - Others .....	17
4. Installation .....	18
4.1. General directions .....	18
4.2. Installation / surrounding conditions.....	18
4.3. Dimensions- Enclosure .....	19
4.4. Installing the hardware.....	21
4.4.1. Introduction .....	21
4.4.2. Terminal connectors with power supply - <u>type : PB / PD / PX</u> .....	22
4.4.3. Terminal connectors with power supply - <u>type : PF / PM</u> .....	26
6. Maintenance.....	31
6.1. General directions .....	31
6.2. Repair.....	31
Appendix A: Technical specification .....	32
Appendix B: Problem solving.....	35
Index of this manual.....	36
List of figures in this manual .....	37

# 1. INTRODUCTION

## 1.1. SYSTEM DESCRIPTION OF THE ERB/RX030

### Functions and features

The batch controller model ERB/Rx030 is a microprocessor driven instrument designed for batching and filling of small batch sizes up to medium large quantities as well as displaying total and accumulated total.

This product has been designed with a focus on:

- ultra-low power consumption to allow long-life battery powered applications (type PB / PC),
- intrinsic safety for use in hazardous applications (type XI),
- several mounting possibilities with GRP or aluminum enclosures for industrial surroundings,
- ability to process all types of flowmeter signals,
- one control output for controlling a pump or valve.

### Flowmeter input

This manual describes the unit with a pulse type input from the flowmeter "-P version". Other versions are available to process (0)4-20mA or 0-10V flowmeter signals.

One flowmeter with a passive or active pulse, Namur or coil signal output can be connected to the ERB/Rx030. To power the sensor, several options are available.

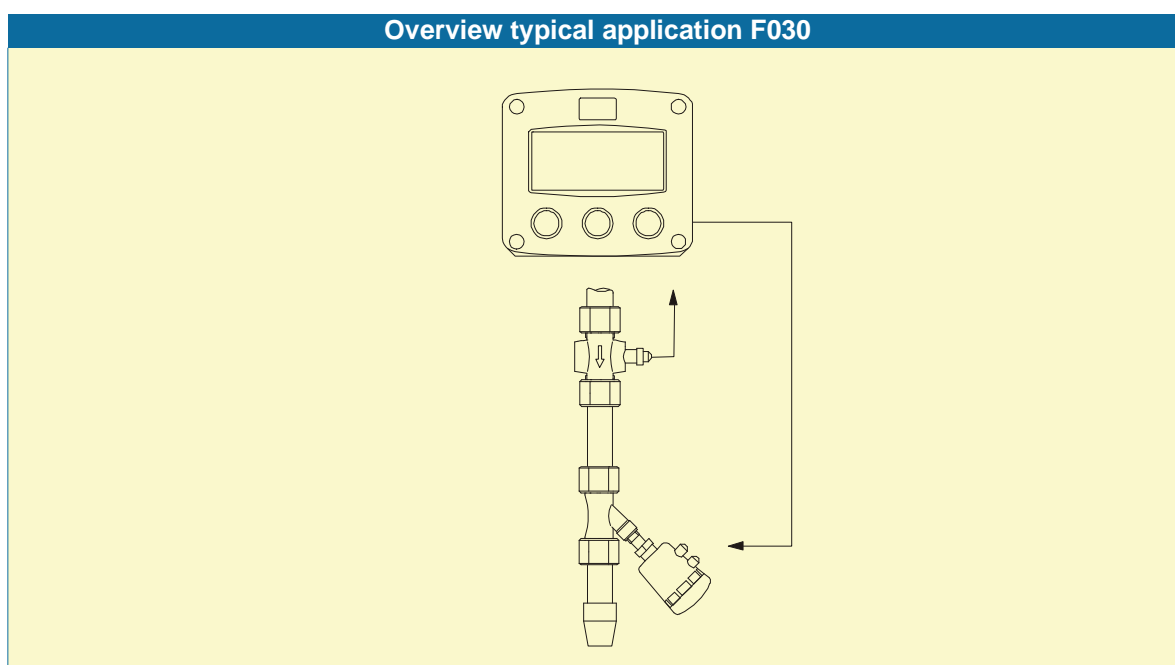

*Fig. 1: Typical application for the ERB/Rx030.*

### Configuration of the unit

The ERB/Rx030 has been designed to be implemented in many types of applications. For that reason, a SETUP-level is available to configure your ERB/Rx030 according to your specific requirements.

It includes several important features, such as K-factors, measurement units, signal selection etc. All settings are stored in EEPROM memory and will not be lost in the event of power failure. To extend the battery-life time, please use of the power-management functions as described in chapter 3.2.3.

### Display information

The unit has a large transreflective LCD with all kinds of symbols and digits to display measuring units, status information, count up or count down and key-word messages.

A backup of the total and accumulated total in EEPROM memory is made every minute.

### Options

The following options are available: intrinsic safety, mechanical relay or active outputs, power- and sensor-supply options, panel-mount, wall-mount and weather-proof enclosures, flame proof enclosure and LED backlight.



## 2. OPERATIONAL

### 2.1. GENERAL



- **The ERB/Rx030 may only be operated by personnel who are authorized and trained by the operator of the facility. All instructions in this manual are to be observed.**
- **Take careful notice of the " Safety rules, instructions and precautionary measures " in the front of this manual.**

This chapter describes the daily use of the ERB/Rx030. This instruction is meant for users / operators.

### 2.2. CONTROL PANEL

The following keys are available:



Fig. 2: Control Panel.

#### Functions of the keys



This key is used to program and save new values or settings.  
It is also used to gain access to SETUP-level; please read chapter 3.



This key is used to START the batch process.  
The arrow-key ▲ is used to increase a value after PROG has been pressed or to configure the unit; please read chapter 3.



Press STOP to "PAUSE" the batch process. When this key is pressed twice, the process is completely finished and can't be continued.  
STOP is also used to select Total and accumulated total.  
After PROG has been pressed, the arrow-key ► is used to select a value

### 2.3. OPERATOR INFORMATION AND FUNCTIONS

In general, the ERB/Rx030 will always act at Operator level. The information displayed is dependant upon the SETUP-settings. All pulses generated by the connected flowmeter are measured by the ERB/Rx030 in the background, whichever screen refresh rate setting is chosen. After pressing a key, the display will be updated very quickly during a 30 second period, after which it will slow-down again.

- **To enter a batch quantity**

To change the PRESET-value, following procedure must be followed:

- 1) press PROG: the word "PROGRAM" will be flashing,
- 2) use ▸ to select the digits and ▲ to increase that value,
- 3) set the new PRESET-value by pressing ENTER.

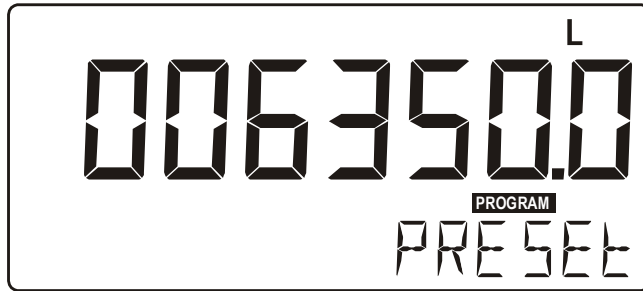

Fig. 3: Example display information during programming preset value.

When data is altered but ENTER has not been pressed yet, then the alteration can still be cancelled by waiting for 20 seconds or by pressing ENTER during three seconds: the former value will be reinstated. The PRESET-value can be used time after time till a new value is programmed.



*Please note that alterations will only be set after ENTER has been pressed!*

Note !

- **Batch maximum**

When you program a new value which is not valid - the batch size is too large - the decrease-sign ▼ will be displayed while you are programming; the new value will not be accepted!

- **Starting up the batch process**

The batch process can only be started up when "READY" is displayed. The batch process is started-up by pressing the START-key.

The arrows at the display indicate if the ACTUAL-value is / was counting up or down.

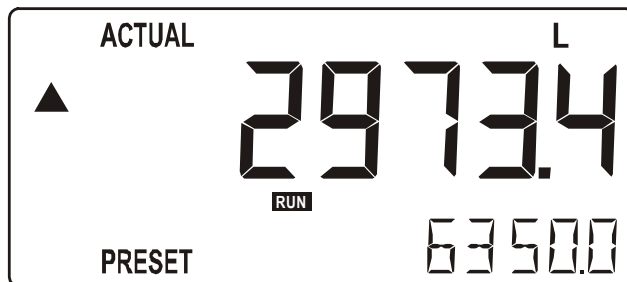

Fig. 4: Example display information during the process.

- **Interrupting and ending the batch process**

When STOP is pressed once, the batch process will be temporarily interrupted; the actual values are not lost. At the display, the word "PAUSE" will be flashing. From this stage, the batch process can be resumed with the START-key.

The process can be ended entirely at all times by pressing STOP twice in which case the actual values are "lost" and the system returns to steady state: the batch can not be resumed.

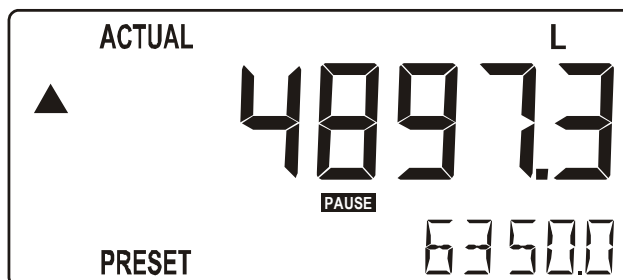

Fig. 5: Example display information when interrupted.

**After batching, following functions are available:**

- **Display total and accumulated total**

When the STOP-key is pressed, total and accumulated total are displayed. The accumulated total cannot be re-initialized. The value will count up to 99,999,999,999. The unit and number of decimals are displayed according to the configuration settings for preset.

- **Clear total**

The value for total can be re-initialized. To do so, select the Total display and press PROG followed by STOP. After pressing PROG, the flashing text "PUSH STOP" is displayed.

To avoid re-initialization at this stage, press another PROG again or wait for 20 seconds. Re-initialization of total DOES NOT influence the accumulated total.

- **Low-battery alarm**

When the battery voltage drops, it must be replaced. At first "low-battery" will flash, but as soon as it is displayed continuously, the battery MUST be replaced shortly after!

Only original batteries supplied by the manufacturer may be used, else the guarantee and liability will be terminated. The remaining lifetime after the first moment of indication is generally several days up to some weeks.



Fig. 6: Example of low-battery alarm.

- **Alarm 01-03**

When "ALARM" is displayed, press the SELECT key to display the reason of the alarm: 1-3. Please consult Appendix B: problem solving.

### 3. CONFIGURATION

#### 3.1. INTRODUCTION

This and the following chapters are exclusively meant for electricians and non-operators. In these, an extensive description of all software settings and hardware connections are provided.



- **Mounting, electrical installation, start-up and maintenance of the instrument may only be carried out by trained personnel authorized by the operator of the facility. Personnel must read and understand this Operating Manual before carrying out its instructions.**
- **The ERB/Rx030 may only be operated by personnel who are authorized and trained by the operator of the facility. All instructions in this manual are to be observed.**
- **Ensure that the measuring system is correctly wired up according to the wiring diagrams. The housing may only be opened by trained personnel.**
- **Take careful notice of the " Safety rules, instructions and precautionary measures " in the front of this manual.**

#### 3.2. PROGRAMMING SETUP-LEVEL

##### 3.2.1. GENERAL

Configuration of the ERB/Rx030 is done at SETUP-level. SETUP-level is reached by pressing the PROG/ENTER key for 7 seconds; at which time, both arrows  $\blacktriangleleft$  will be displayed. In order to return to the operator level, PROG will have to be pressed for three seconds. Alternatively, if no keys are pressed for 2 minutes, the unit will exit SETUP automatically. SETUP can be reached at all times while the ERB/Rx030 remains fully operational.

 **Note:** A pass code may be required to enter SETUP. Without this pass code access to SETUP is denied.

To enter SETUP-level:

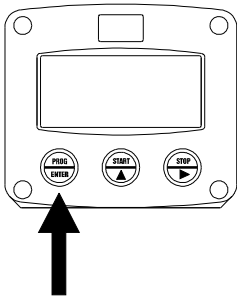

Press  for 7 seconds

Matrix structure SETUP-level:

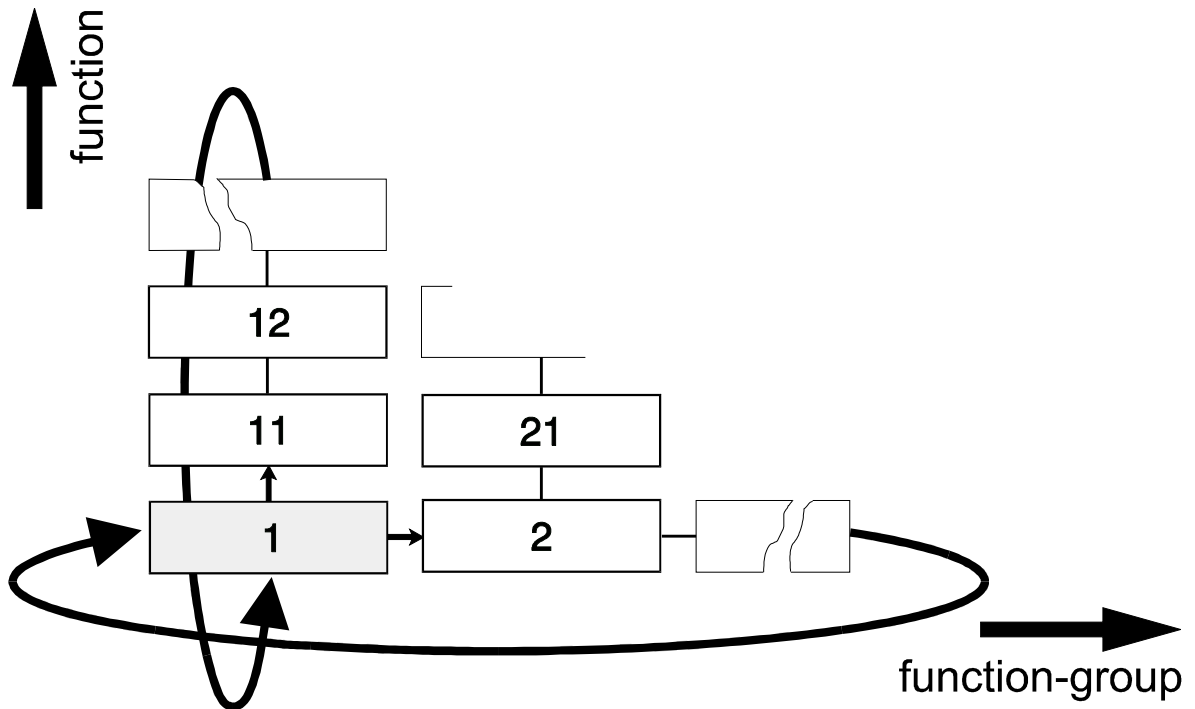

SCROLLING THROUGH SETUP-LEVEL

Selection of function-group and function:

SETUP is divided into several function groups and functions.

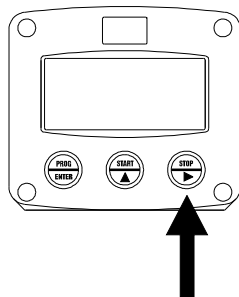

Select function-group with

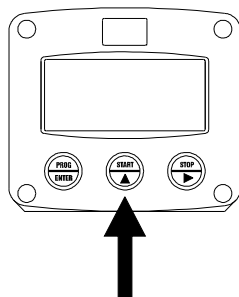

Select function with







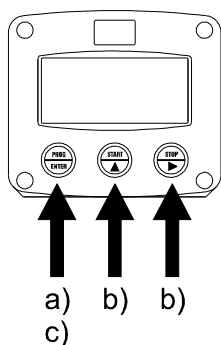

Each function has a unique number, which is displayed below the word "SETUP" at the bottom of the display. The number is a combination of two figures. The first figure indicates the function-group and the second figure the sub-function. Additionally, each function is expressed with a keyword.



After selecting a sub-function, the next main function is selected by scrolling through all "active" sub-functions (e.g. 1<sup>▲</sup>, 11<sup>▲</sup>, 12<sup>▲</sup>, 13<sup>▲</sup>, 14<sup>▲</sup>, 1<sup>▶</sup>, 2<sup>▶</sup>, 3<sup>▲</sup>, 31 etc.).



To change or select a value:



- a) press  briefly; **PROGRAM** will start flash
- b) select or enter value with  and / or 
- c) press  to confirm the value / selection.

To change a value, use  to select the digits and  to increase that value.

To select a setting, both  and  can be used.

If the new value is invalid, the increase sign  or decrease-sign  will be displayed while you are programming.

When data is altered but ENTER is not pressed, then the alteration can still be cancelled by waiting for 20 seconds or by pressing ENTER for three seconds: the PROG-procedure will be left automatically and the former value reinstated.



Note !

**Note:** alterations will only be set after ENTER has been pressed!

To return to OPERATOR-level:

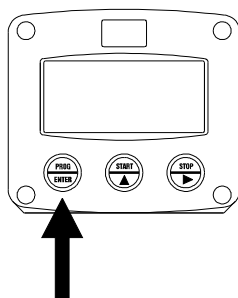

Press  for 3 seconds

In order to return to the operator level, PROG will have to be pressed for three seconds. Also, when no keys are pressed for 2 minutes, SETUP will be left automatically.

## 3.2.2. OVERVIEW FUNCTIONS SETUP LEVEL

SETUP FUNCTIONS AND VARIABLES			
<b>1</b>	<b>PRESET</b>		
	11	UNIT	L - m3 - kg - lb - GAL - USGAL - bbl - no unit
	12	DECIMALS	0 - 1 - 2 - 3 (Ref: displayed value)
	13	K-FACTOR:	0.000010 - 9,999,999
	14	DECIMALS K-FACTOR	0 - 6
	15	BATCH MAXIMUM	X,XXX,XXX quantity
<b>2</b>	<b>OVERRUN</b>		
	21	OVERRUN	disable - enable
	22	TIME	0.1 - 999.9 seconds
<b>3</b>	<b>DISPLAY</b>		
	31	DISPLAY	increase - decrease
	32	BACKLIGHT (optional)	off - green - amber
	33	BL. BRIGHTNESS	1 - 5
<b>4</b>	<b>POWER MANAGEMENT</b>		
	41	LCD UPDATE	fast - 1 sec - 3 sec - 15 sec - 30 sec - off
	42	BATTERY MODE	operational - shelf
<b>5</b>	<b>FLOWMETER</b>		
	51	SIGNAL	nnp - npn_lp - reed - reed_lp - pnp - pnp_lp - namur - coil_hi - coil_lo - act_8.1 - act_12 - act_24
<b>6</b>	<b>OTHERS</b>		
	61	TYPE / MODEL	ERB/Rx030
	62	SOFTWARE VERSION	v03._._._
	63	SERIAL NO.	_____
	64	PASSWORD	0000 - 9999
	65	TAGNUMBER	0000000 - 9999999

## 3.2.3. EXPLANATION OF SETUP-FUNCTIONS

<b>1 - PRESET</b>	
<b>MEASUREMENT UNIT 11</b>	<p>SETUP - 11 determines the measurement unit for preset, total, accumulated total and pulse output. The following units can be selected:</p> <p style="text-align: center;">L - m3 - kg - lb. - GAL - USGAL - bbl - _ (no unit).</p> <p>Alteration of the measurement unit will have consequences for operator and SETUP-level values. Please note that the K-factor has to be adapted as well; the calculation is not done automatically.</p>
<b>DECIMALS 12</b>	<p>The decimal point determines for preset, total and accumulated total the number of digits following the decimal point. The following can be selected:</p> <p style="text-align: center;">0000000 - 111111.1 - 22222.22 - 3333.333</p>
<b>K-FACTOR 13</b>	<p>With the K-factor, the flowmeter pulse signals are converted to a quantity. The K-factor is based on the number of pulses generated by the flowmeter per selected measurement unit (SETUP 11), for example per cubic meter. The more accurate the K-factor, the more accurate the functioning of the system will be.</p> <p><b>Example 1: Calculating the K-factor.</b> <i>Let us assume that the flowmeter generates 2.4813 pulses per liter and the selected unit is "cubic meters / m3". A cubic meter consists of 1000 parts of one liter which implies 2,481.3 pulses per m3. So, the K-factor is 2,481.3. Enter for SETUP - 13: "2481300" and for SETUP - 14 - decimals K-factor "3".</i></p> <p><b>Example 2: Calculating the K-factor.</b> <i>Let us assume that the flowmeter generates 6.5231 pulses per gallon and the selected measurement unit is gallons. So, the K-Factor is 6.5231. Enter for SETUP - 13: "6523100" and for SETUP - 14 decimals K-factor "6".</i></p>
<b>DECIMALS K-FACTOR 14</b>	<p>This setting determines the number of decimals for the K-factor entered. (SETUP 13). The following can be selected:</p> <p style="text-align: center;">0 - 1 - 2 - 3 - 4 - 5 - 6</p> <p>Please note that this setting influences the accuracy of the K-factor indirectly. (i.e. the position of the decimal point and thus the value given) This setting has NO influence on the displayed number of digits for total (SETUP 12)!</p>
<b>BATCH MAXIMUM 15</b>	<p>This function limits the operator to enter a new preset-value which is more as the entered batch maximum.</p>

## 2 - OVERRUN

Overrun can occur at the end of the batch process, as a result of slowness of a valve / pump. Consequently, the accuracy is less. With this function, the ERB/Rx030 analyses the actual overrun characteristic after every batch. This information is used to correct the overrun automatically.

<b>OVERRUN</b> 21	For an accurate overrun correction, it is necessary that the flow meter meets certain technical demands, such as "high resolution" and shows no "false" overrun due to a slow update time. Do not enable this function if the flow meter does not meet these technical demands.
<b>OVERRUN TIME</b> 22	The overrun characteristic of the system will be analyzed during a certain time after the batch. In this way, false signal generated through leakage are eliminated. Enter here the expected time needed by the system to stop a batch. It is advisable to provide extra time in order to avoid an incorrect overrun correction or false leakage alarms. <i>Note that the next batch can only be started after elapsing of this overrun time!</i> The minimum overrun time is 0.1 second, maximum 999.9 seconds.

## 3 - DISPLAY

<b>DISPLAY</b> 31	The large 17mm digits can be set to display the actual batched quantity (increase) OR to display the remaining quantity to be batched (decrease).
The functions below will only effect the optional LED-backlight.	
<b>BACKLIGHT (OPTION)</b> 32	If a LED backlight has been supplied, the color can be selected. Following selections are available:  <p style="text-align: center;">OFF - GREEN - AMBER</p>
<b>BRIGHTNESS (OPTION)</b> 33	The density of the backlight can be set in the range: 1 - 5  One is minimum and five is maximum brightness.

## 4 - POWER MANAGEMENT

When used with the internal battery option, the user can expect reliable measurement over a long period of time. The ERB/Rx030 has several smart power management functions to extend the battery life time significantly. Two of these functions can be set:

<b>LCD NEW</b> 41	The calculation of the display-information influences the power consumption significantly. When the application does not require a fast display update, it is <b>strongly advised</b> to select a slow refresh rate. Please understand that NO information will be lost; every pulse will be counted and the output signals will be generated in the normal way. The following can be selected:  <p style="text-align: center;">Fast - 1 sec - 3 sec - 15 sec - 30 sec - off.</p> <b>Example 3: Battery life-time</b> <i>coil pick-up, 1KHz. pulses and FAST update: about 2 years.</i> <i>coil pick-up, 1KHz. pulses and 1 sec update: about 5 years.</i>  <b>Note:</b> after a button has been pressed by the operator - the display refresh rate will always switch to FAST for 30 seconds. When "OFF" is selected, the display will be switched off after 30 seconds and will be switched on as soon as a button has been pressed.
<b>BATTERY-MODE</b> 42	The unit has two modes: operational or shelf. After "shelf" has been selected, the unit can be stored for several years; it will not count pulses, the display is switched off but all settings and totals are stored. In this mode, power consumption is extremely low. To wake up the unit again, press the SELECT-key twice.



Note !



Note !

5 - FLOWMETER				
<b>SIGNAL</b> 51	The ERB/Rx030 is able to handle several types of input signal. The type of flowmeter pickup / signal is selected with SETUP 51. <b>Note:</b> The selections "active pulse" offer a detection level of 50% of the supply voltage. Read also par. 4.4.3. Flowmeter input terminal 09-11.			
TYPE OF SIGNAL	EXPLANATION	RESISTANCE	FREQ. / mV	REMARK
NPN	NPN input	100kOhm pull-up	6 kHz.	(open collector)
NPN - LP	NPN input with low pass filter	100kOhm pull-up	1.2 kHz.	(open collector) less sensitive
REED	Reed-switch input	1mOhm pull-up	600 Hz.	
REED - LP	Reed-switch input with low pass filter	1mOhm pull-up	120 Hz.	Less sensitive
PNP	PNP input	47kOhm pull-down	6 kHz.	
PNP - LP	PNP input with low pass filter	100kOhm pull-down	1.2 kHz.	Less sensitive
NAMUR	Namur input	820 Ohm pull-down	4 kHz.	External power required
COIL HI	High sensitive coil input	-	20mV p.t.p.	Sensitive for disturbance!
COIL LO	Low sensitive coil input	-	90mV p.t.p.	Normal sensitivity
ACTIVE	Active pulse input detection level 1.2V DC	47kOhm	10KHz.	External power required

6 - OTHERS	
<b>TYPE OF MODEL</b> 61	For support and maintenance it is important to have information about the characteristics of the ERB/Rx030. Your supplier will ask for this information in the case of a serious breakdown or to assess the suitability of your model for upgrade considerations.
<b>VERSION SOFTWARE</b> 62	For support and maintenance it is important to have information about the characteristics of the ERB/Rx030. Your supplier will ask for this information in the case of a serious breakdown or to assess the suitability of your model for upgrade considerations.
<b>SERIAL NUMBER</b> 63	For support and maintenance it is important to have information about the characteristics of the ERB/Rx030. Your supplier will ask for this information in the case of a serious breakdown or to assess the suitability of your model for upgrade considerations.
<b>PASS CODE</b> 64	All SETUP-values can be pass code protected. This protection is disabled with value 0000 (zero). Up to and including 4 digits can be programmed, for example 1234.
<b>TAGNUMBER</b> 65	For identification of the unit and communication purposes, a unique tag number of maximum 7 digits can be entered.

## 4. INSTALLATION

### 4.1. GENERAL DIRECTIONS



- **Mounting, electrical installation, start-up and maintenance of this instrument may only be carried out by trained personnel authorized by the operator of the facility. Personnel must read and understand this Operating Manual before carrying out its instructions.**
- **The ERB/Rx030 may only be operated by personnel who are authorized and trained by the operator of the facility. All instructions in this manual are to be observed.**
- **Ensure that the measuring system is correctly wired up according to the wiring diagrams. Protection against accidental contact is no longer assured when the housing cover is removed or the panel cabinet has been opened (danger from electrical shock). The housing may only be opened by trained personnel.**
- **Take careful notice of the " Safety rules, instructions and precautionary measures " at the front of this manual.**

### 4.2. INSTALLATION / SURROUNDING CONDITIONS

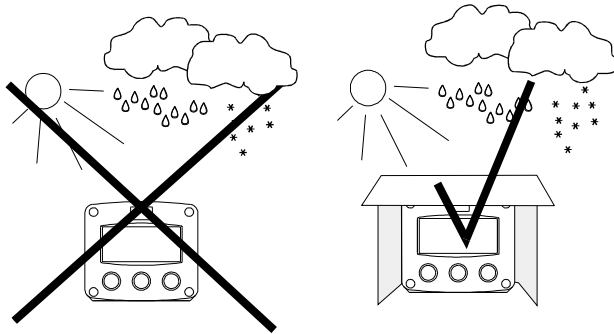

Take the relevant IP classification of the casing into account (see manufactures plate). Even an IP67 (NEMA 4X) casing should NEVER be exposed to strongly varying (weather) conditions. When panel-mounted, the unit is IP65 (NEMA 4)!

When used in very cold surroundings or varying climatic conditions, take the necessary precautions against moisture by placing a dry sachet of silica gel, for example, inside the instrument case.

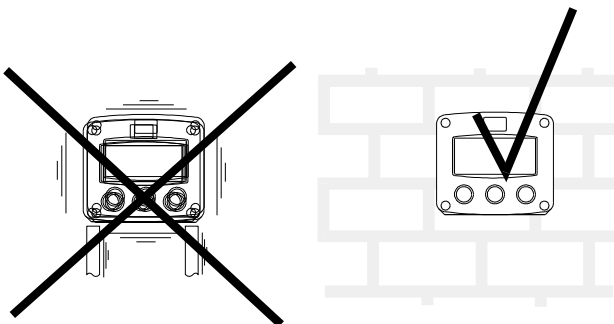

Mount the ERB/Rx030 on a solid structure to avoid vibrations.

4.3. DIMENSIONS- ENCLOSURE

Aluminum enclosures:

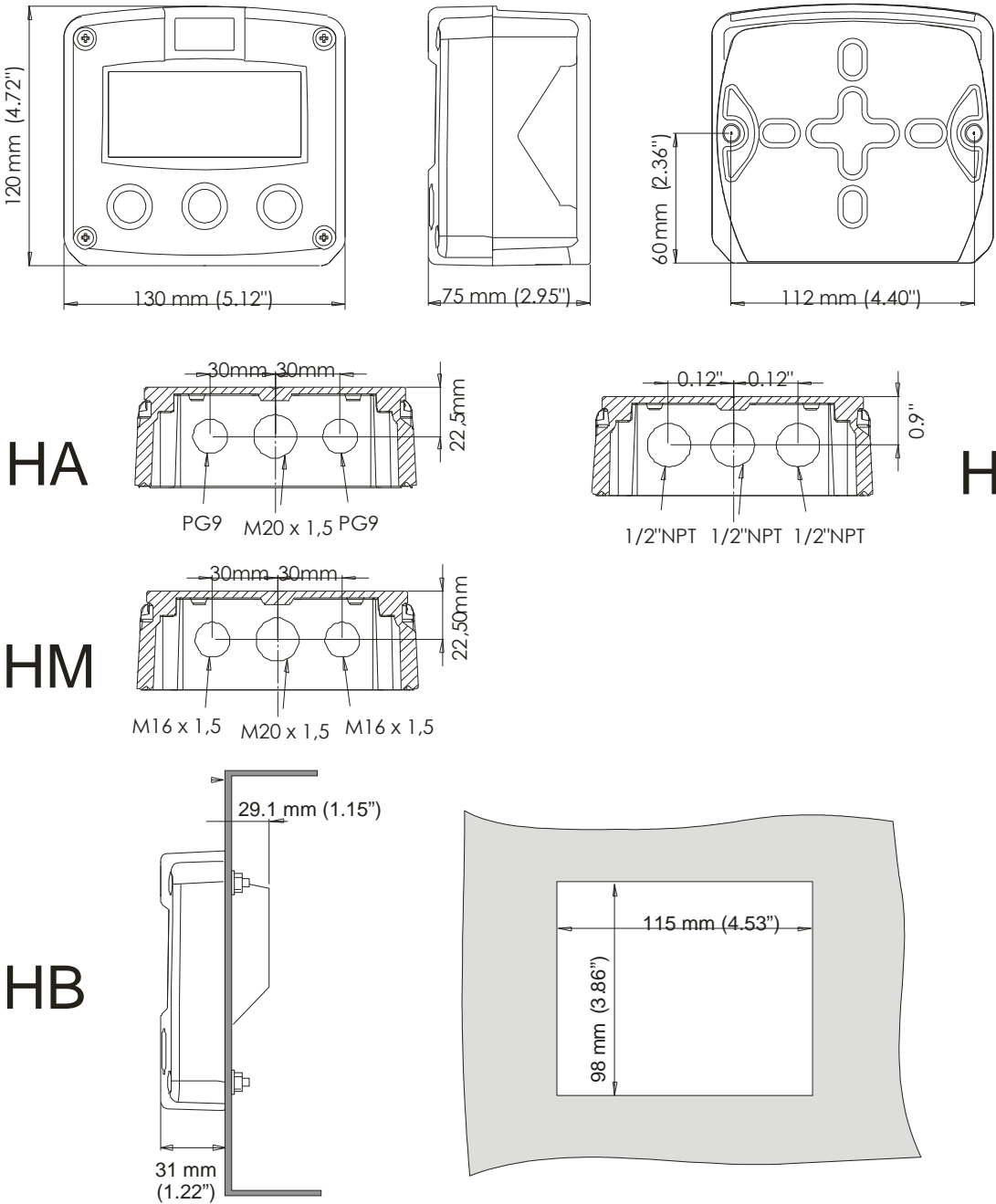

Fig. 7: Dimensions Aluminum enclosures.

GRP enclosures:

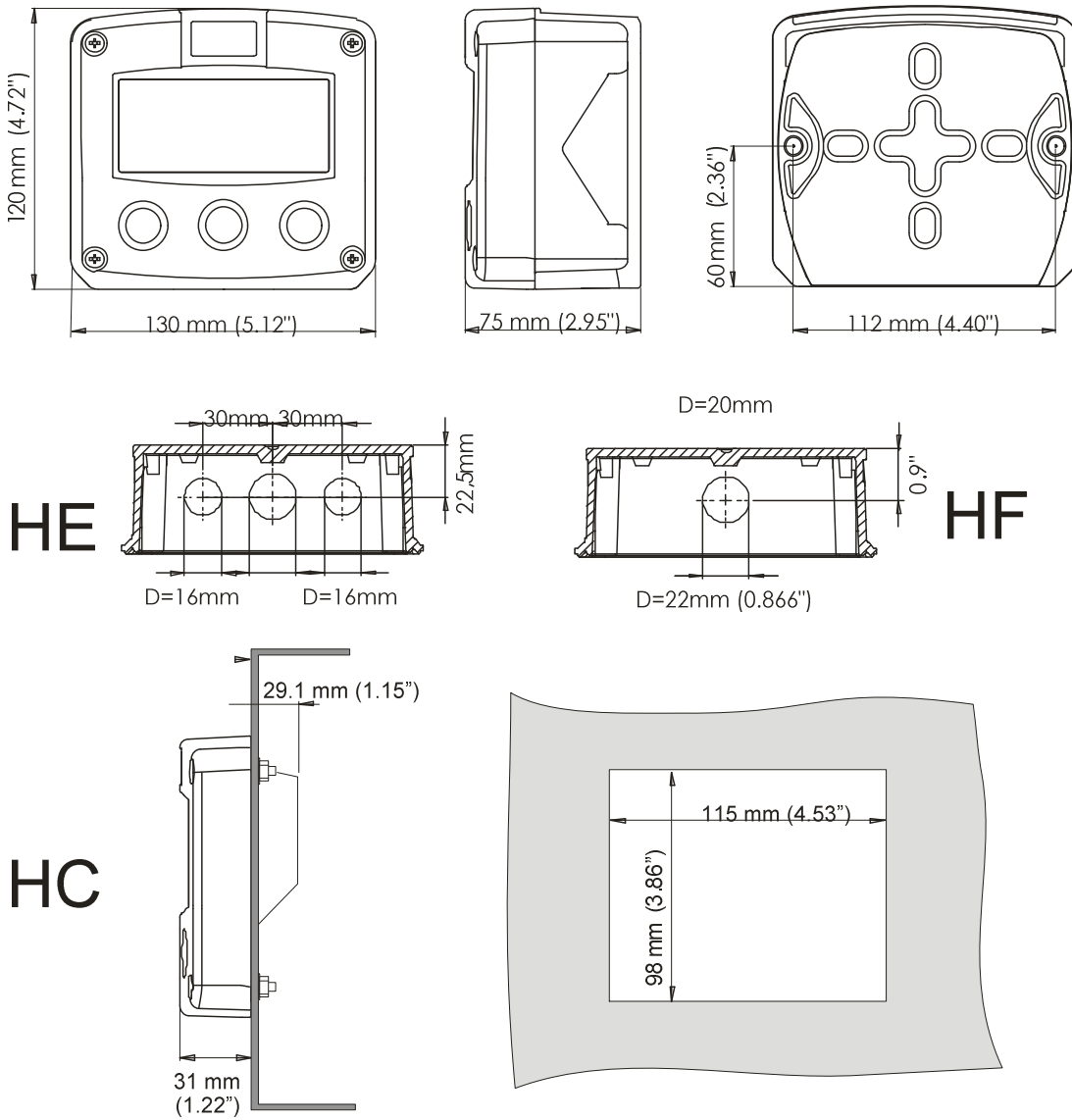

Fig. 8: Dimensions GRP enclosures.

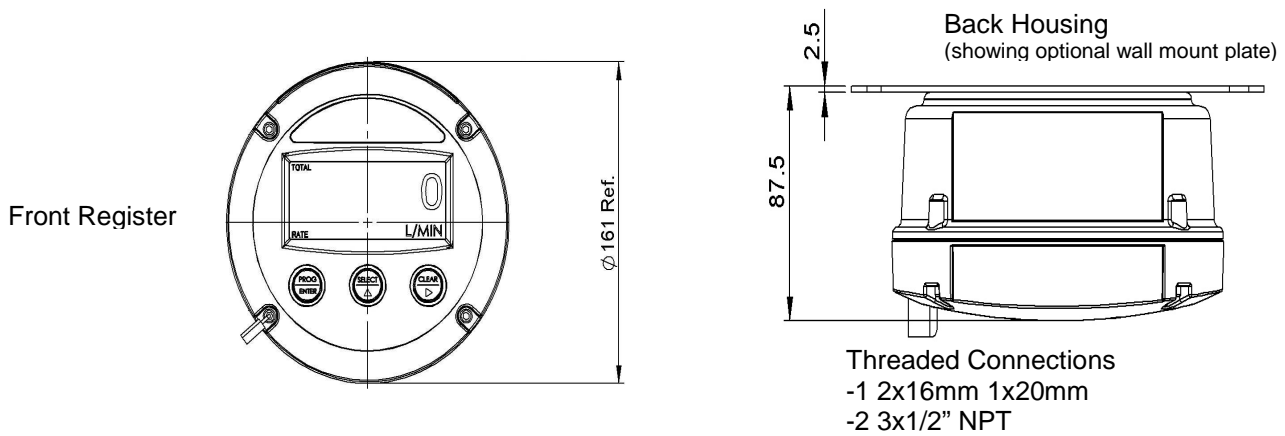

Fig. 6a: Dimensions ER Series meter mount enclosures

#### 4.4. INSTALLING THE HARDWARE

##### 4.4.1. INTRODUCTION



- **Electro static discharge does inflict irreparable damage to electronics! Before installing or opening the unit, the installer has to discharge himself by touching a well-grounded object.**



- **This unit must be installed in accordance with the EMC guidelines (Electro Magnetic Compatibility).**



- **Do ground the aluminum casing properly as indicated, if the ERB/Rx030 has been supplied with the 115-230V AC power-supply type PM. The green / yellow wire between the back-casing and removable terminal-block may never be removed.**

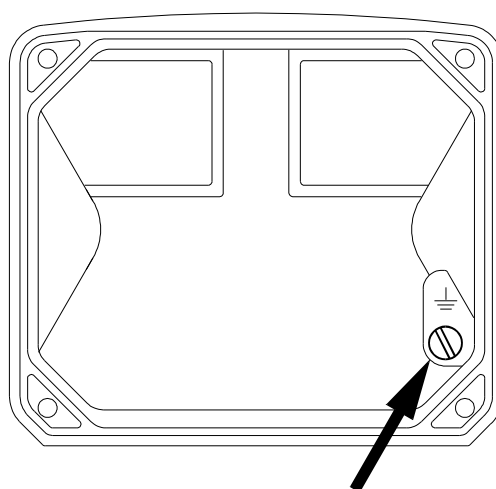

Fig. 9: Grounding aluminum enclosure with option PM 115-230V AC.

#### FOR INSTALLATION, PAY EMPHATIC ATTENTION TO:

- Separate cable glands with effective IP67 (NEMA4X) seals for all wires.
- Unused cable entries: ensure that you fit IP67 (NEMA4X) plugs to maintain rating.
- A reliable ground connection for both the sensor, and if applicable, for the metal casing. (above)
- An effective screened cable for the input signal, and grounding of it's screen to the "⊥" terminal or at the sensor itself, whichever is appropriate to the application.

4.4.2. **TERMINAL CONNECTORS WITH POWER SUPPLY - TYPE : PB / PD / PX**

The following terminal connectors are available:

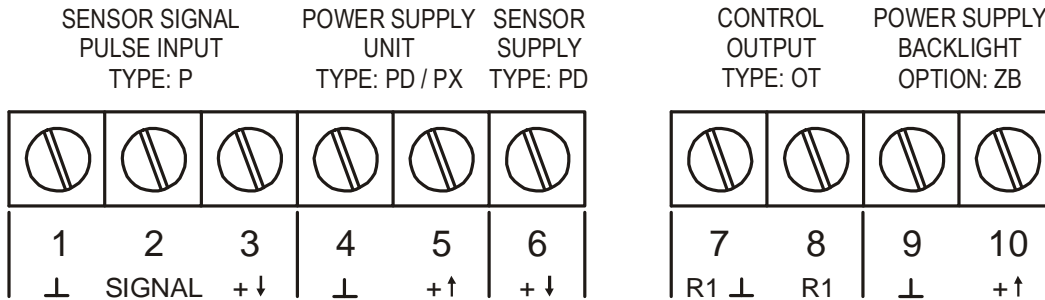

Fig. 10: Overview of terminal connectors ERB/Rx030-(PB / PD / PX) and options.

**SENSOR SUPPLY**

**Type PB / PD / PX - terminal 3: sensor supply 1.2V - 3.2V:**

Terminal 3 provides a limited supply voltage of 3.2 V DC (coil signals 1.2V) for the signal output of the flowmeter.

**Note:** This voltage MAY NOT be used to power the flowmeters electronics, converters etc, as it will not provide adequate sustained power ! All energy used by the flowmeters pick-up will directly influence the battery life-time (type PB). It is strongly advised to use a "zero power" pickup such as a coil or reed-switch when operating without external power. It is possible to use some low power NPN or PNP output signals, but the battery life time will be significantly reduced (consult your distributor).



Note !

**Type PD - terminal 6: sensor supply 8.2V:**

With this option, a basic but real sensor supply of max. 5mA@8.2V is available to power e.g. a Namur sensor.

**REMARKS: TERMINAL CONNECTORS:****Terminals 1-3; Flowmeter input:**

Three basic types of flowmeter signals can be connected to the unit: pulse, active pulse or coil. The screen of the signal wire must be connected to the common ground terminal

The input signal type has to be selected with the correct SETUP-function (read par. 3.2.3.)

**Coil-signal:**

The ERB/Rx030 is suitable for use with flowmeters which have a coil output signal.

Two sensitivity levels can be selected with the SETUP-function:

COIL LO: sensitivity from about 90mVp-p.

COIL HI: sensitivity from about 20mVp-p.

Type ZF (option): offers for setting COIL HI : sensitivity from about 10mVp-p.

Type ZG (option): offers for setting COIL HI : sensitivity from about 5mVp-p.

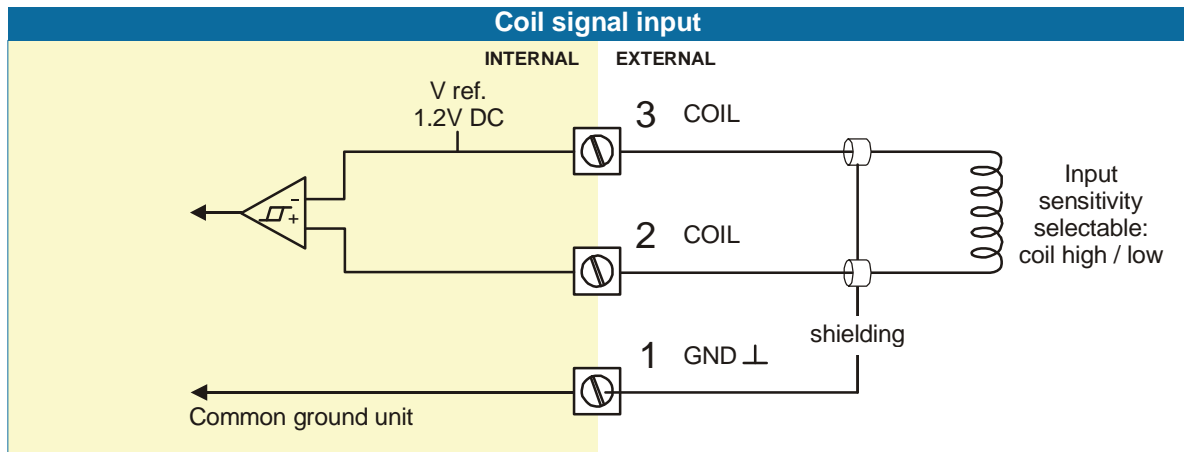
**Pulse-signal NPN / NPN-LP:**

The ERB/Rx030 is suitable for use with flowmeters which have a NPN output signal. For reliable pulse detection, the pulse amplitude has to go below 1.2V. Signal setting NPN-LP employs a low-pass signal noise filter, which limits the maximum input frequency - read par. 3.2.3.

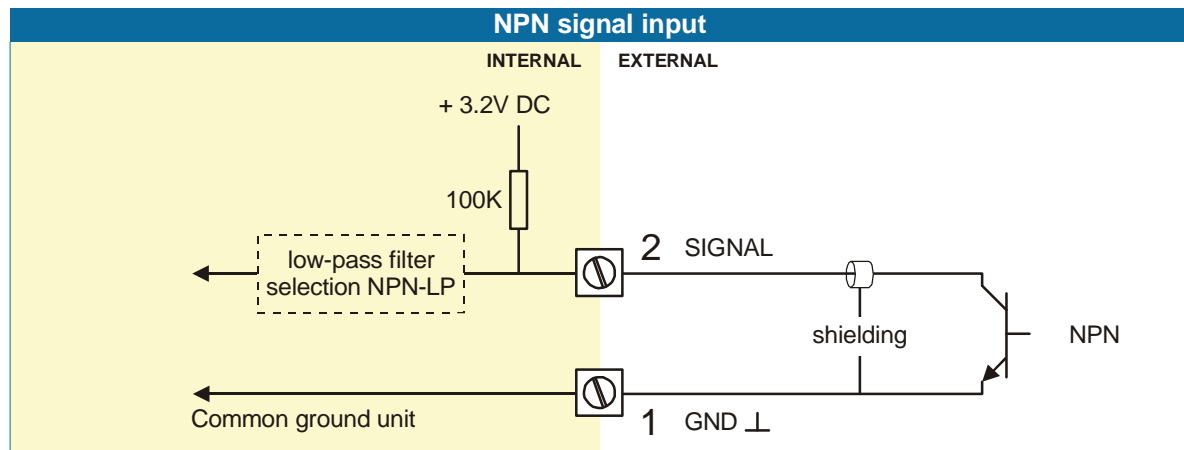

**Pulse-signal PNP / PNP-LP:**

The ERB/Rx030 is suitable for use with flowmeters which have a PNP output signal. Terminal 3 offers 3.2V which has to be switched by the sensor to terminal 2 (SIGNAL). For a reliable pulse detection, the pulse amplitude has to go above 1.2V. Signal setting PNP-LP employs a low-pass signal noise filter, which limits the maximum input frequency - read par. 3.2.3. A sensor supply voltage of 8.1V DC can be provided with option PD on terminal 6.

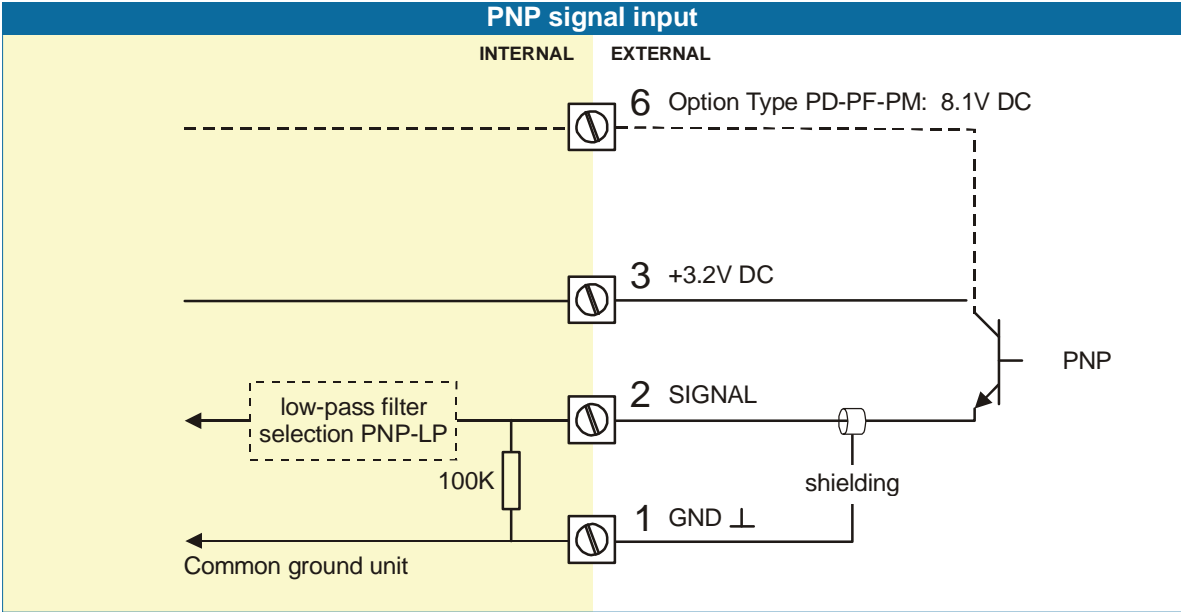

**Active signals:**

Active signal selection may well be desired in the case of option PD being supplied for sensorsupply.

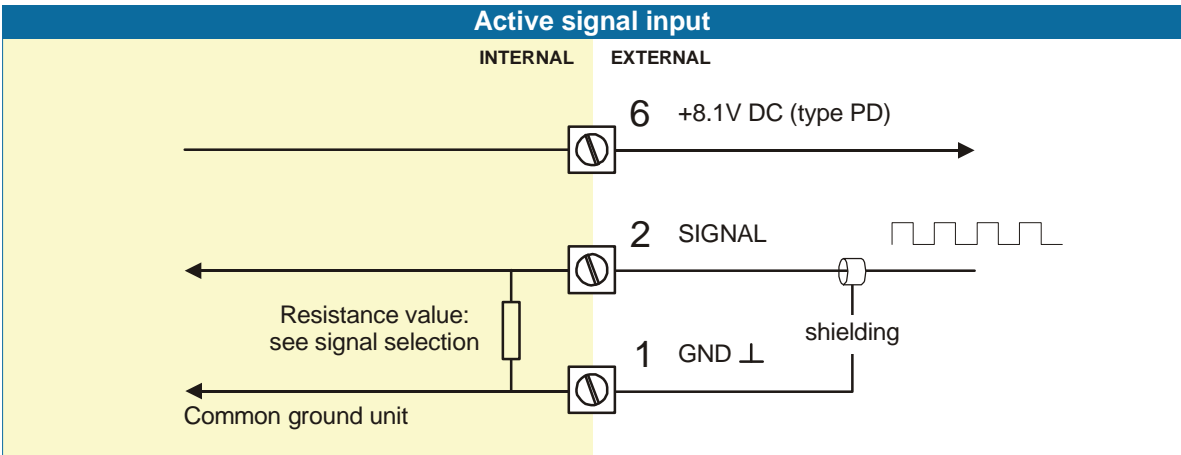

**Reed-switch:**

The ERB/Rx030 is suitable for use with flowmeters which have a reed-switch. To avoid pulse bounce from the reed-switch, it is advised to select REED LP - low-pass filter (read par. 3.2.3.)

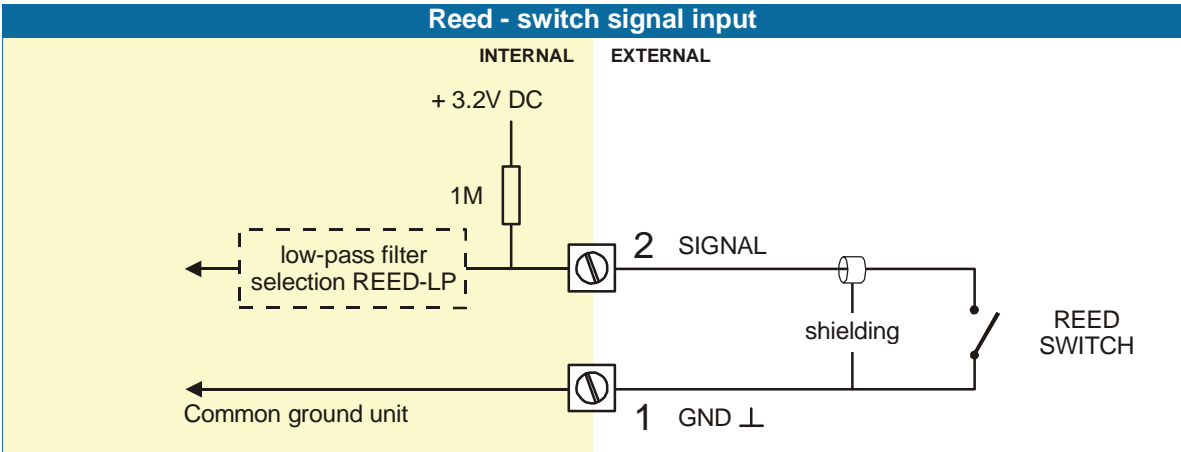

**NAMUR-signal:**

The ERB/Rx030 is suitable for flowmeters with an Namur signal. The standard ERB/Rx030 is not able to power the Namur sensor, as an external power supply for the sensor is required. However, a 8.2V sensor supply voltage (terminal 6) can be provided with type PD.

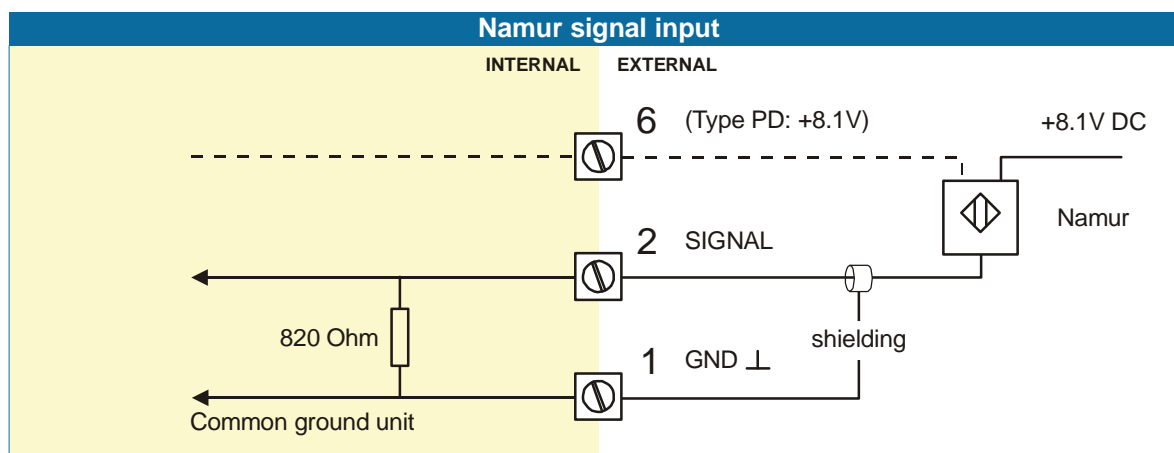
**Terminal 4-5: POWER SUPPLY UNIT - TYPE PD / PX:**

To power the unit an internal battery can be used (type PB) and / or an external DC power supply of 8-30V DC (type PX) or 16-30V DC (type PD).

Connect the "-" to terminal 4 and the "+" to terminal 5. When power is applied to these terminals, the optional internal battery will be disabled / enabled automatically to extend the battery life time.

**Terminal 6: Power supply type PD: 8.2V sensor supply.**

With this option, a limited power supply for the sensor is available, for example to power a Namur sensor. It offers 8.2V DC (max. 5mA).

Remark: this terminal is only available if option PD has been ordered.

**Terminal 7-8: Control output:**

This passive transistor output controls the valve or pump for the batch process.

Maximum switch power 300mA@50V DC.

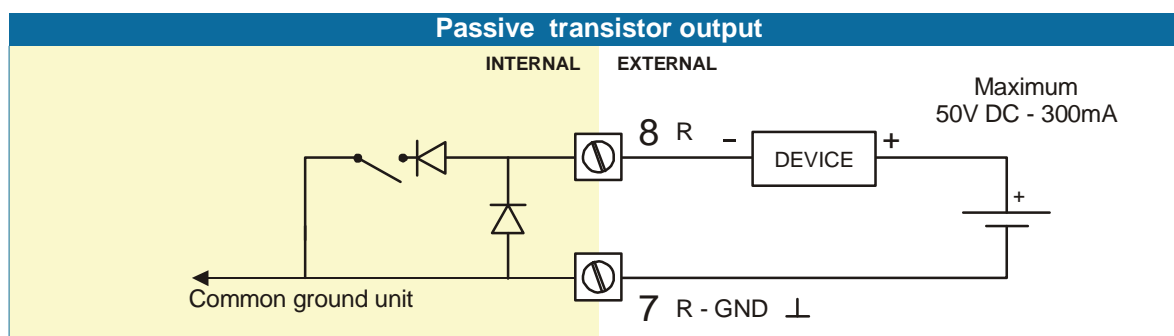
**Terminal 9-10: Power supply backlight - type ZB (option):**

To power the backlight, a voltage in the range 20-30V DC has to be connected.

Maximum current 30mA. Connect the "-" to terminal 9 and the "+" to terminal 10.

4.4.3. **TERMINAL CONNECTORS WITH POWER SUPPLY - TYPE : PF / PM**

The following terminal connectors are available:

POWER SUPPLY TYPE: PF / PM			CONTROL OUTPUT TYPE: OA-OR-OT		SENSOR SIGNAL TYPE: P: PULSE INPUT		
GND ⊥	1 N	2 L1	3 R⊥	4 R	5 ⊥	6 SIGNAL	7 +↓

Fig. 11: Overview of terminal connectors ERB/Rx030-(PF / PM) and options.

**SENSOR SUPPLY**

**Type PF / PM: Sensor supply: 1.2, 3.2V, 8.2V, 12V or 24 V:**

With this option, a real power supply for the sensor is available. The flowmeter can be powered with 1.2, 3.2, 8.2, 12 or 24 V DC (max. 400mA@24V). The voltage is selected with the three switches inside the enclosure.



- **Warning: be sure that all the leads to the terminals are disconnected from the unit when the internal plastic protection cover has been removed !**
- **HIGH VOLTAGE 400V !! NEVER connect the mains power supply to the unit when the plastic protection cover has been removed !!!**

First, remove the terminal strip(s) after which the internal plastic cover can be removed. The switches are located on the right hand side as indicated:

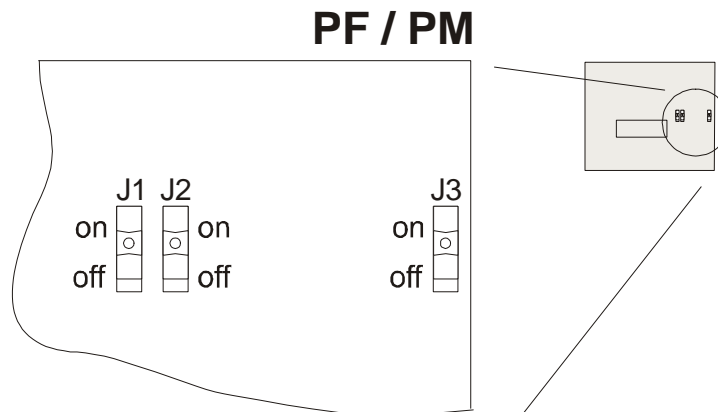

Fig. 12: switch position voltage selection (type PF and PM).

**Switch positions / sensor supply voltage:**

VOLTAGE SELECTION				
SWITCH	1.2 / 3.2V DC	8.2V DC	12V DC	24V DC
J1	on	off	off	off
J2	on or off	on	on	off
J3	on or off	on	off	on or off

**REMARKS: TERMINAL CONNECTORS:**

Terminal GND- 01- 02; **POWER SUPPLY** only available with type PF / PM:

OPTION	SENSOR SUPPLY	Terminal		
		GND	01	02
PF 24V AC $\pm$ 10%	1.2, 3.2, 8.2, 12, 24V max. 400mA@24V DC		AC	AC
PF 24V DC $\pm$ 10%	1.2, 3.2, 8.2, 12, 24V max. 400mA@24V DC	L-	L+	
PM 115-230V AC $\pm$ 10%	1.2, 3.2, 8.2, 12, 24V max. 400mA@24V DC	EARTH	AC	AC
Note PF / PM	The total consumption of the sensor, transistor output type OA and backlight type ZB may not exceed 400mA@24V DC.			

**Terminal 3-4; Control output:**

This output controls the valve or pump for the batch process.

**Type OA:**

An active 24V DC transistor output is available with this option.

Max. driving capacity 400mA@24V DC. (Requires power supply type PF / PM).

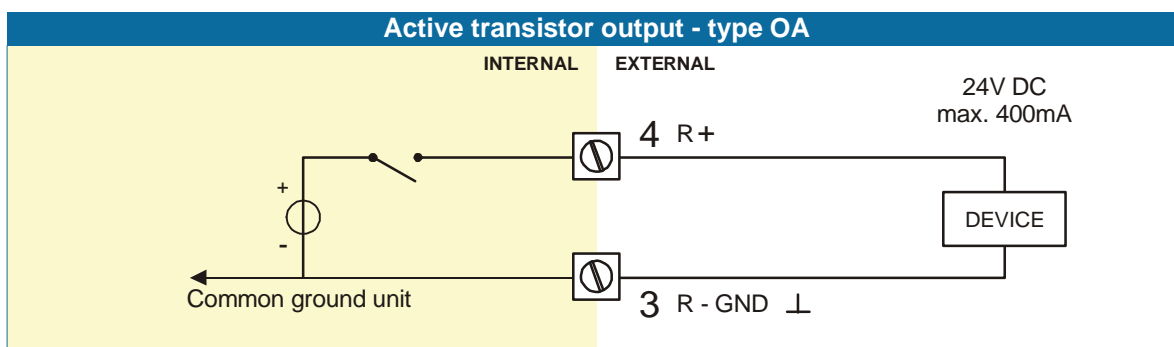

**Type OR:**

An isolated mechanical relay output is available with this option.

Max. switch power 240V 0,5A. (Requires power supply type PF / PM).

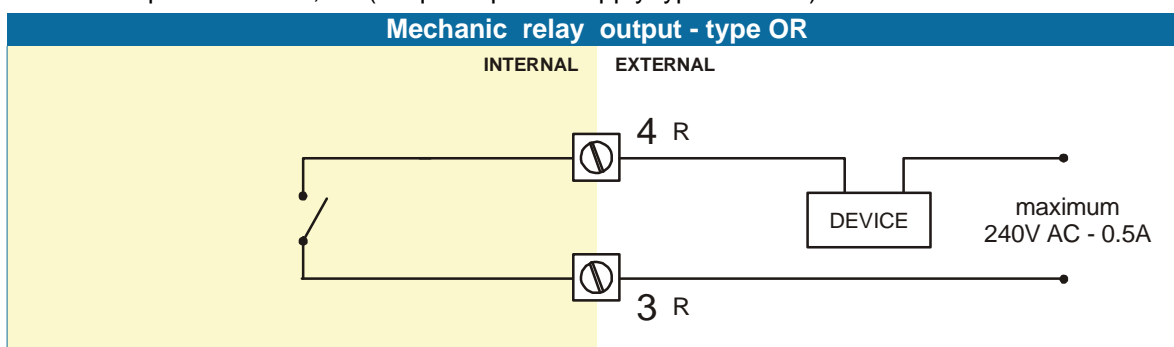

**Type OT:**

A passive transistor output is available with this option. Max. driving capacity 300mA@50V DC.

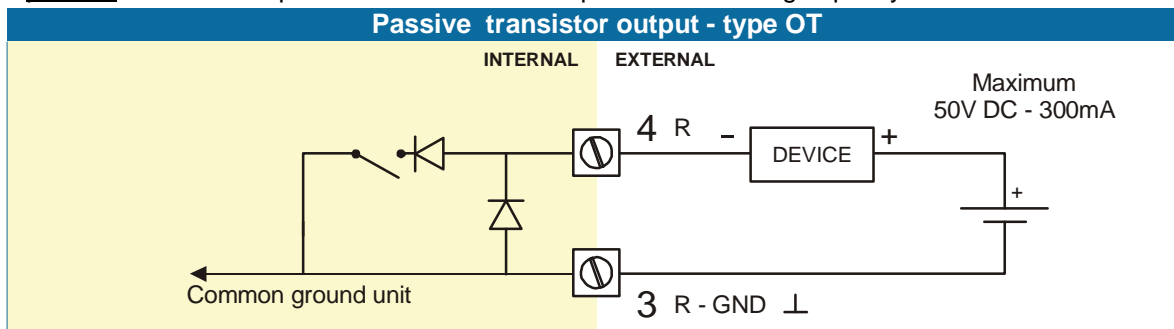

**Terminals 5-7; Flowmeter input:**

Three basic types of flowmeter signals can be connected to the unit: pulse, active pulse or coil. The screen of the signal wire must be connected to the common ground terminal  
 The input signal type has to be selected with the correct SETUP-function (read par. 3.2.3.)

**Coil-signal:**

The ERB/Rx030 is suitable for use with flowmeters which have a coil output signal.

Two sensitivity levels can be selected with the SETUP-function:

COIL LO: sensitivity from about 90mVp-p.

COIL HI: sensitivity from about 20mVp-p.

Type ZF (option): offers for setting COIL HI : sensitivity from about 10mVp-p.

Type ZG (option): offers for setting COIL HI : sensitivity from about 5mVp-p.

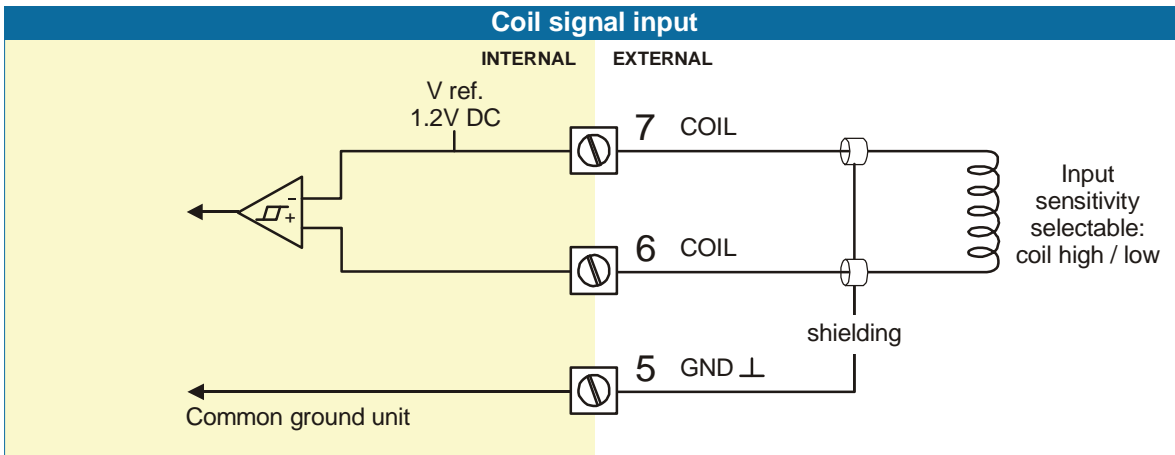

**Pulse-signal NPN / NPN-LP:**

The ERB/Rx030 is suitable for use with flowmeters which have a NPN output signal. For reliable pulse detection, the pulse amplitude has to go below 1.2V. Signal setting NPN-LP employs a low-pass signal noise filter, which limits the maximum input frequency - read par. 3.2.3.

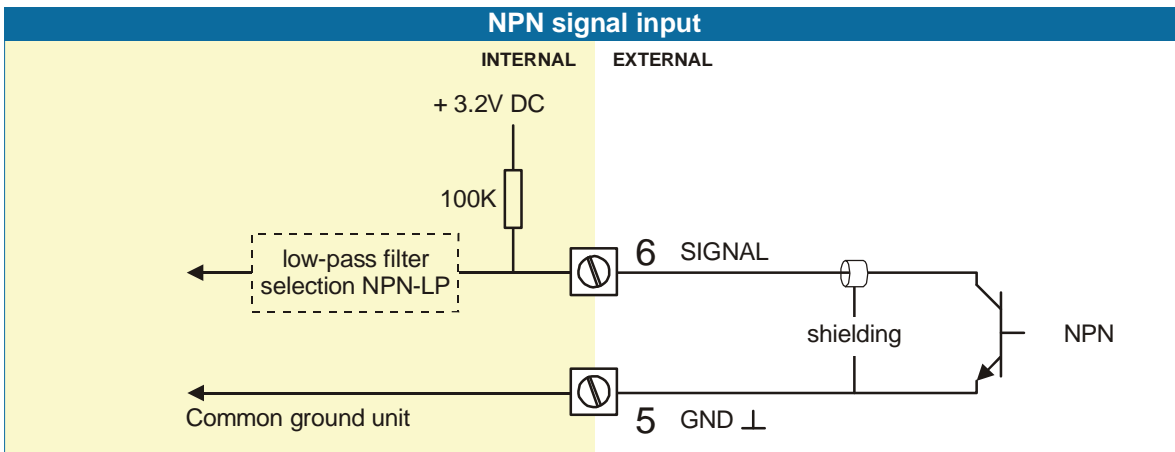

**Pulse-signal PNP / PNP-LP:**

The ERB/Rx030 is suitable for use with flowmeters which have a PNP output signal. For a reliable pulse detection, the pulse amplitude has to go above 1.2V. Signal setting PNP-LP employs a low-pass signal noise filter, which limits the maximum input frequency - read par. 3.2.3. A sensor supply voltage is offered with terminal 7.

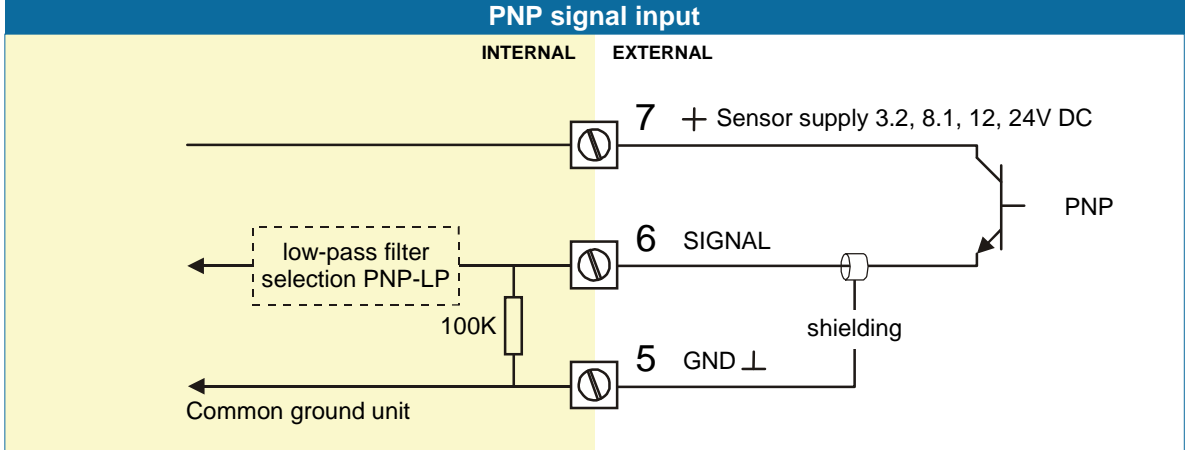

**Active signal:**

Active signal selection may well be desired if an active signal is offered from the sensor.

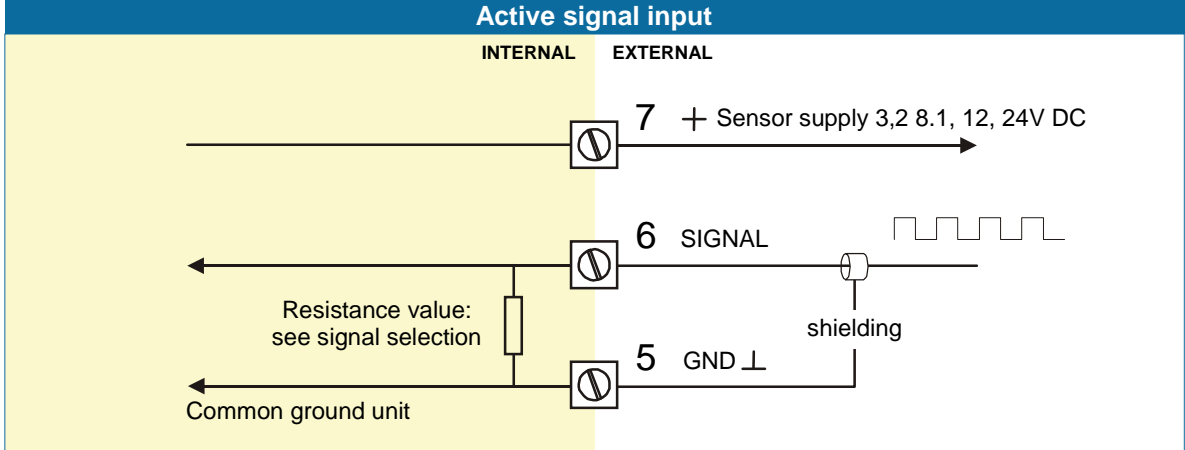

**Reed-switch:**

The ERB/Rx030 is suitable for use with flowmeters which have a reed-switch. To avoid pulse bounce from the reed-switch, it is advised to select REED LP - low-pass filter (read par. 3.2.3.)

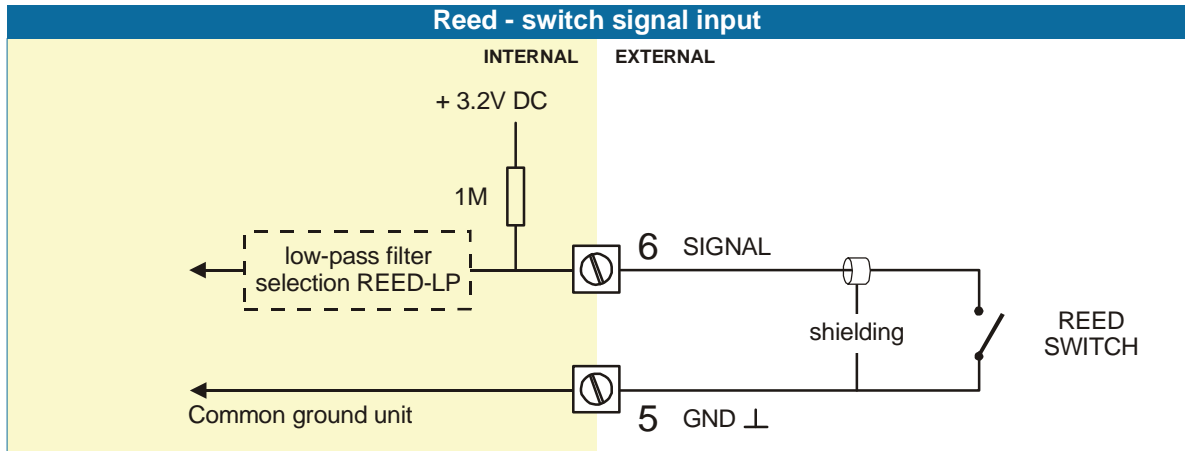

**NAMUR-signal:**

The ERB/Rx030 is suitable for flowmeters with an Namur signal.

Terminal 7 can provide a 8.2V sensor supply voltage (please read section “sensor supply”).

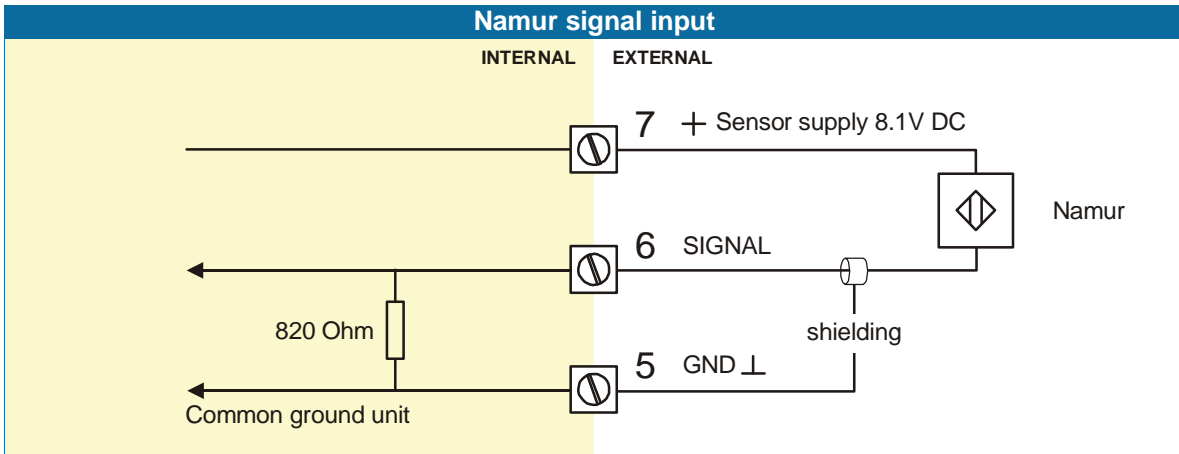

**Serial number and year of production**

This information can be looked-up on the display: setup function (par. 3.2.2.).

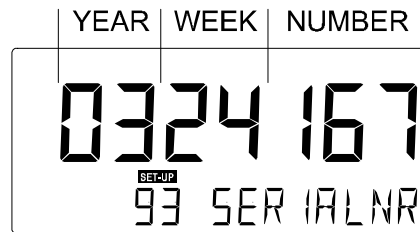

Fig. 13: Example serial number.

## 6. MAINTENANCE

### 6.1. GENERAL DIRECTIONS



- **Mounting, electrical installation, start-up and maintenance of the instrument may only be carried out by trained personnel authorized by the operator of the facility. Personnel must read and understand this Operating Manual before carrying out its instructions.**
- **The ERB/Rx030 may only be operated by personnel who are authorized and trained by the operator of the facility. All instructions in this manual are to be observed.**
- **Ensure that the measuring system is correctly wired up according to the wiring diagrams. Protection against accidental contact is no longer assured when the housing cover is removed or the panel cabinet has been opened (danger from electrical shock). The housing may only be opened by trained personnel.**
- **Take careful notice of the " Safety rules, instructions and precautionary measures " in the front of this manual.**

The ERB/Rx030 does not require special maintenance unless it is used in low-temperature applications or surroundings with high humidity (above 90% annual mean). It is the users responsibility to take all precautions to dehumidify the internal atmosphere of the ERB/Rx030 in such a way that no condensation will occur, for example by placing dry silica-gel sachet in the casing just before closing it. Furthermore, it is required to replace or dry the silica gel periodically as advised by the silica gel supplier.

#### **Battery life-time:**

It is influenced by several issues :

- Type of sensor: read chapter 3.2.3. NPN and PNP inputs consume more energy than coil inputs.
- Input frequency: the higher the frequency, the shorter the battery life-time.
- Display update: fast display update uses significantly more power; SETUP 41.
- Low temperatures; the available power will be less due to battery chemistry.



Note !

**Note:** *It is strongly advised to disable unused functions.*

#### **Check periodically:**

- The condition of the casing, cable glands and front panel.
- The input/output wiring for reliability and aging symptoms.
- The process accuracy. As a result of wear and tear, re-calibration of the flowmeter might be necessary. Do not forget to re-enter any subsequent K-factor alterations.
- The indication for low-battery.
- Clean the casing with soapy-water. Do not use any aggressive solvents as these might damage the coating.

### 6.2. REPAIR

This product cannot be repaired by the user and must be replaced with an equivalent certified product. Repairs should only be carried out by the manufacturer or his authorized agent.

## APPENDIX A: TECHNICAL SPECIFICATION

### GENERAL

Display	
Type	High intensity reflective numeric and alphanumeric LCD, UV-resistant.
Digits	Seven 17mm (0.67") and eleven 8mm (0.31"). Various symbols and measuring units.
Refresh rate	User definable: 8 times/sec - 30 secs.
Option type ZB	Bi-color configurable LED-backlight - green or amber. Intensity adjustable from the keyboard.

Enclosures	
General	Die-cast aluminum or GRP (Glassfibre Reinforced Polyamide) enclosure with Polycarbonate window, silicone and EPDM gaskets. UV stabilized and flame retardant material.
Control Keys	Three industrial micro-switch keys. UV-resistant silicone keypad.
Painting	Aluminum enclosure only: UV-resistant 2-component industrial painting.
Panel-mount enclosures	Dimensions: 130 x 120 x 60mm (5.10" x 4.72" x 2.38") – LxHxD.
Classification	IP65 / NEMA4
Panel cut-out	115 x 98mm (4.53" x 3.86") LxH.
Type HC	GRP panel-mount enclosure
Type HB	Aluminum panel-mount enclosure
Field/wall-mount enclosures	Dimensions: 130 x 120 x 75mm (5.10" x 4.72" x 2.95") – LxHxD.
Classification	IP67 / NEMA4X
Aluminum enclosures	
Type HA	Drilling: 2x PG9 – 1x M20.
Type HM	Drilling: 2x M16 – 1x M20.
Type HR	Drilling: 2 x M16 & 1 x M20 – 3 x ½" NPT
Type HU	Drilling: 3x ½"NPT.
GRP enclosures	
Type HD	No drilling.
Type HE	Drilling: 2x 16mm (0.63") – 1x 20mm (0.78").
Type HF	Drilling: 1x 22mm (0.87").
Type HG	Drilling: 2x 20mm (0.78").
Option ZS	Silicone free ABS enclosure with EPDM and PE gaskets. UV-resistant polyester keypad. Note: this option comes with type HD only.

Operating temperature	
Operational	-40°C to +80°C (-40°F to +178°F).
Intrinsically Safe	-40°C to +70°C (-40°F to +158°F).

Power requirements	
Type PB	Lithium battery - life-time depends upon settings - up to 5 years.
Type PC	Intrinsically Safe lithium battery - life-time depends upon settings - up to 5 years.
Type PD	16-30 V DC. Power consumption max. 1 Watt.
Type PF	24V AC/DC ±10%. Power consumption max. 15 Watt.
Type PL	Input loop powered from 4-20mA signal input. Voltage drop max. 2.6V DC
Type PM	115-230V AC ±10%. Power consumption max. 15 Watt.
Type PX	8-30 V DC (also available with PB / PC). Power consumption max. 0.3 Watt.
Type ZB	20-30V DC. Power consumption max. 1 Watt. Note: with type PF / PM: internally powered.
Note PF / PM	The total consumption of the sensor, active output type OA and backlight type ZB may not exceed 400mA@24V DC.
Note I.S. application	for intrinsically safe applications, consult the safety values in the certificate.

Sensor excitation	
Type PB / PC / PL / PX	Sensor supply voltage: 3.2V DC for pulse signals and 1.2V DC for coil pick-up. Please note: this is not a real sensor supply. Only suitable for sensors with a very low power consumption like coils (sine wave) and reed-switches. Analog sensors type A / U: sensor supply not available.
Type PD	With pulse input type P: sensor supply voltage 1.2, 3.2, 8.2V DC - max. 5mA@8.2V DC. With analog input type A / U: as connected power supply voltage (internally linked)
Type PF / PM	Sensor supply voltage 1.2, 3.2, 8.2, 12 and 24V DC - max. 400mA@24V DC

Terminal connections	
Type:	Removable plug-in terminal strip. Wire max. 1.5mm <sup>2</sup> and 2.5mm <sup>2</sup>

Data protection	
Type	EEPROM backup of all setting. Backup of running totals every minute. Data retention at least 10 years.
Pass code	Configuration settings can be pass code protected.

Hazardous area (option)	
Intrinsically safe Type XI	ATEX approval ref.: <EX> II 1 GD EEx ia IIC T4 T100°C IECEx, CSA and FM approval is expected to be available Q1 2007.
Explosion proof Type XF	ATEX approval ref.: <EX> II 2 GD EEx d IIB T5. Weight appr. 15kg. Dimensions of enclosure: 350 x 250 x 200mm (13.7" x 9.9" x 7.9") LxHxD.

Environment	
Electromagnetic compatibility	Compliant ref: EN 61326 (1997), EN 61010-1 (1993)
Low voltage directive	Compliant ref: EN60950.

## INPUTS

Flowmeter	
Type P	Coil/sine wave (minimum 20mVpp or 80mVp-p - sensitivity selectable), NPN/PNP, open collector, reed-switch, Namur, active pulse signals.
Frequency	Minimum 0 Hz - maximum 7 kHz for total and flowrate. Maximum frequency depends on signal type and internal low-pass filter. E.g. Reed switch with low-pass filter: max. frequency 120 Hz.
K-Factor	0.000010 - 9,999,999 with variable decimal position.
Low-pass filter	Available for all pulse signals.
Type A	(0)4-20mA - with signal calibration feature.
Type U	0-10 V - with signal calibration feature.
Accuracy	Resolution: 16 bit.. Error < 0.01mA / ±0.05% FS. Low level cut-off programmable.
Span	0.000010 - 9,999,999 with variable decimal position.
Update time	Four times a second.
Voltage drop	2.5 Volt.
Load impedance	3kOhm
Relationship	Linear and square root calculation.
Note	For signal type A and U: external power to sensor is required; e.g. type PD.

**OUTPUT**

<b>Control output</b>	
Function	Batch process one stage control output.
Type OT	One passive transistor output - not isolated. Load max. 50V DC - 300mA.
Type OA	One active 24V DC transistor output; max. 400mA per output (requires type PF or PM).
Type OR	One mechanic relay output; max. switch power 230V AC - 0,5A (requires type PF or PM).

**OPERATIONAL**

<b>Operator functions</b>	
Functions	<ul style="list-style-type: none"> <li>• enter a preset value,</li> <li>• start / interrupt and stop the batch process,</li> <li>• total can be reset to zero.</li> </ul>
Displayed information	<ul style="list-style-type: none"> <li>• preset value</li> <li>• running batch total or remaining quantity,</li> <li>• total and accumulated total.</li> </ul>

<b>Preset / Total</b>	
Digits	7 digits.
Units	L, m3, GAL, USGAL, KG, lb, bbl, no unit.
Decimals	0 - 1 - 2 or 3.
Note	total can be reset to zero.

<b>Accumulated total</b>	
Digits	11 digits.
Units / decimals	according to selection for total.

## APPENDIX B: PROBLEM SOLVING

In this appendix, several problems are included that can occur when the ERB/Rx030 is going to be installed or while it is in operation.

### Flowmeter does not generate pulses:

Check:

- Signal selection SETUP - 51,
- Pulse amplitude (par. 4.4.),
- Flowmeter, wiring and connection of terminal connectors (par. 4.4.),
- Power supply of flowmeter (par. 4.4.).

### Flowmeter generates "too many pulses":

Check:

- Settings for total: SETUP 11-14,
- Type of signal selected with actual signal generated - SETUP - 51,
- Sensitivity of coil input - SETUP - 51 and par. 4.4.
- Proper grounding of the ERB/Rx030 - par. 4.4.
- Use screened wire for flowmeter signals and connect screen to terminal 9. (unless connected at sensor)

### The pass code is unknown:

If the pass code is not 1234, there is only one possibility left: call your supplier.

### ALARM

When the alarm flag starts to blink an internal alarm condition has occurred. Press the "select button" several times to display the 4-digit error code. The codes are:

- 0001: irrecoverable display-data error: data on the display might be corrupted.
- 0002: irrecoverable data-storage error: the programming cycle might have gone wrong: check programmed values.
- 0003: error 1 and error 2 occurred simultaneously

The alarm condition will almost certainly be handled internally and if all mentioned values still appear correct, no intervention by the operator is needed. If the alarm occurs more often or stays active for a longer time, please contact your supplier.

## INDEX OF THIS MANUAL

accumulated Total	8	Operator level	7
active pulse signal	22, 27	pass code	15, 37
actual settings	40	power supply	23, 25
alarm	8, 37	preset	
backlight	23	max. batch size	13
color	14	Preset	
density	14	batch maximum	7
batch maximum	7	enter batch value	7
battery life time	14, 33	Problem solving	37
Clear Total	8	pulse-signal NPN	21, 26
coil-signal	21, 26	pulse-signal PNP	22, 27
Configuration	9	reed-switch:	22, 27
control output	23, 25	repair	33
Dimensions	17	sensor supply voltage	20, 23, 24
display		serial number	15
function	14	SETUP-level	9
display update	14	START	7
flowmeter		STOP	8
signal	15	subfunction	10
flowmeter input	21, 26	tagnumber	15
Installation	16	Technical specification	34
IIP classification	16	terminal connectors	20, 24
keys	6	total	
low-battery	8	decimals	13
Low-battery alarm	8	decimals k-factor	13
main-function	10	k-factor	13
maintenance	33	measuring unit	13
model	15	version software	15
namur signal	23, 28	voltage selection sensor supply	24

## LIST OF FIGURES IN THIS MANUAL

Fig. 1: Typical application for the ERB/Rx030. ....	5
Fig. 2: Control Panel.....	7
Fig. 3: Example display information during programming preset value. ....	8
Fig. 4: Example display information during the process. ....	8
Fig. 5: Example display information when interrupted. ....	9
Fig. 6: Example of low-battery alarm.....	9
Fig. 7: Dimensions Aluminum enclosures. ....	19
Fig. 8: Dimensions GRP enclosures. ....	20
Fig. 9: Grounding aluminum enclosure with option PM 115-230V AC.....	21
Fig. 10: Overview of terminal connectors ERB/Rx030-(PB / PD / PX) and options.....	22
Fig. 11: Overview of terminal connectors ERB/Rx030-(PF / PM) and options. ....	26
Fig. 12: switch position voltage selection (type PF and PM).....	26
Fig. 13: Example serial number. ....	30

LIST OF CONFIGURATION SETTINGS			
SETTING	DEFAULT	DATE :	DATE :
<b>1 - PRESET</b>	Enter your settings here		
11 unit	L		
12 decimals	0000000		
13 K-factor	0000001		
14 decimals K-factor	0		
15 max. batch size	0		
<b>2 - OVERRUN</b>			
21 overrun	disabled		
22 overrun quantity	0 L		
<b>3 - DISPLAY</b>			
31 display	increase		
<b>4 - POWER MANAGEMENT</b>			
41 LCD-new	1 sec.		
42 mode	operational		
<b>5 - FLOWMETER</b>			
51 signal	coil-lo		
<b>6 - OTHERS</b>			
61 model	ERB/Rx030	ERB/Rx030	ERB/Rx030
62 software version	03.____.____	03.____.____	03.____.____
63 serial number	-----	-----	-----
64 pass code	0000		
65 tagnumber	0000000		